

P503

DPI Coupling Network up to 1 GHz, 50 V

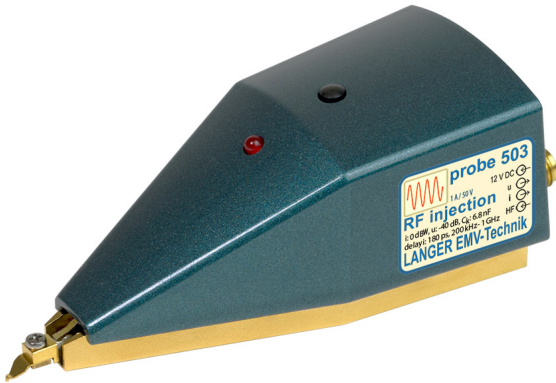

Short description

The P503 DPI coupling network is designed for RF direct power injection (DPI) in IC pins according to IEC 62132-4. Current and voltage can be measured separately during the power injection via integrated measuring outputs. The P503 coupling network is connected to a power amplifier.

Technical parameters

Coupling capacity	3 μ F
Voltage probe	without preamplifier
Frequency range	16 kHz ... 3 GHz
Measurement output	50 Ω , SMB
Transfer factor	-40 dB
Ammeter /current probe	with preamplifier
-1 dB compression point (output)	120 dB μ V
Frequency range	200 kHz ... 1 GHz
IP3	134 dB μ V
Correction curve R (2MHz - 1 GHz), typical	0 dB Ω (= 1 V/A)
Correction curve R (200 kHz - 2 MHz) [dB Ω]	characteristic curve
Measurement output	50 Ω , SMB
Noise figure	4.5 dB
Delay from current to voltage, typical	240 ps
Supply voltage	12 V/DC
Max. input voltage RF	50 V _{eff}
Max. input current RF	1 A
Connector - input	50 Ω , SMA

Frequency response

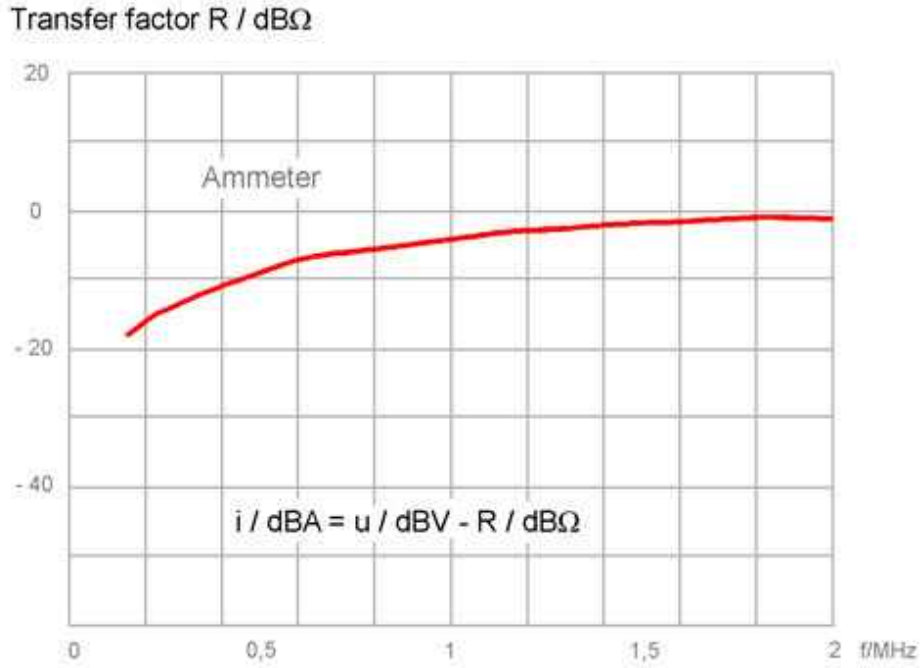

Equivalent circuit

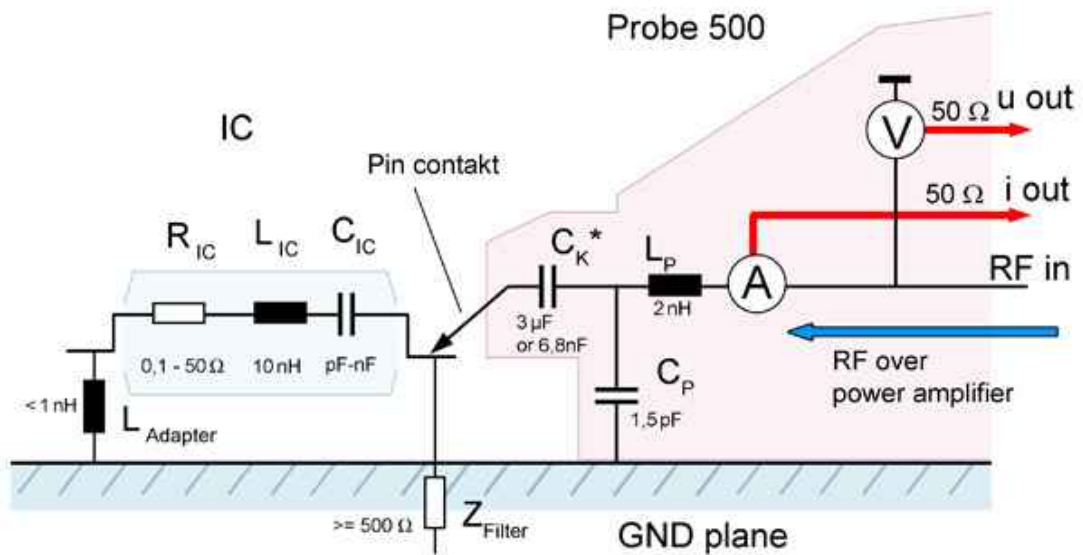

P503

DPI Coupling Network up to 1 GHz, 50 V

Design, view 1

