

**LANGER**  
EMV-Technik

# IC TEST SYSTEM

User Manual

**P603-1 / P750 set**  
RF conducted measurement  
IEC 61967-4

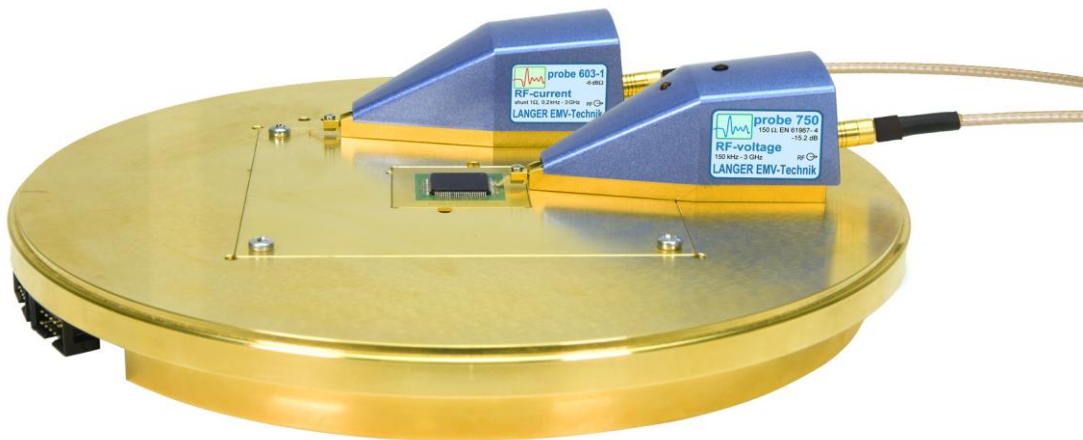

<b>Contents:</b>	<b>Page</b>
<b>1 Declaration of Conformity .....</b>	<b>3</b>
<b>2 General Information .....</b>	<b>4</b>
2.1 Storage of the User Manual .....	4
2.2 Reading and Understanding the User Manual .....	4
2.3 Local Safety and Accident Prevention Regulations .....	4
2.4 Images .....	4
2.5 Limitation of Liability .....	4
2.6 Errors and Omissions .....	4
2.7 Copyright .....	4
<b>3 Scope of Delivery .....</b>	<b>5</b>
<b>4 Technical Parameters .....</b>	<b>6</b>
4.1 P603-1 Probe .....	6
4.2 P750 Probe .....	7
<b>5 Safety .....</b>	<b>8</b>
5.1 Labels and Signs .....	8
5.2 Intended Use .....	8
5.3 Reasonably foreseeable Misuse .....	12
5.4 Staff Requisition .....	12
5.5 Safety Instructions .....	13
<b>6 P603-1 Probe.....</b>	<b>14</b>
6.1 General Description.....	14
6.2 Design and Function of the P603-1 Probe .....	14
<b>7 P750 Probe.....</b>	<b>16</b>
7.1 General Description.....	16
7.2 Design and Function of the P750 Probe .....	16
<b>8 Contact Detection.....</b>	<b>18</b>
<b>9 Measurement Set-up .....</b>	<b>19</b>
9.1 Performing the Measurement .....	19
<b>10 Using the ChipScan-ESA Software.....</b>	<b>22</b>
<b>11 Information on Recycling and Disposal .....</b>	<b>28</b>
<b>12 Customer service .....</b>	<b>29</b>
<b>13 Warranty.....</b>	<b>30</b>

# 1 Declaration of Conformity



Manufacturer:  
Langer EMV-Technik GmbH

Nöthnitzer Hang 31  
01728 Bannewitz  
Germany

Langer EMV-Technik GmbH herewith declares that the

**P603-1 / P750 set, RF conducted measurement** including  
P603-1; P750

conforms with the following relevant regulations:

- EMC Directive 2014/30/EU
- Low-Voltage Directive 2014/35/EU
- Restriction of certain Hazardous Substances 2011/65/EU

The following applicable standards were used to implement the requirements specified by the a forementioned directives:

- DIN EN IEC 61000-6-1:2019-11 (EMC immunity)
- DIN EN IEC 61000-6-3:2022-06 (EMC emission)
- DIN EN 61010-1:2020-03 (Safety)
- DIN EN IEC 63000:2019-05 (Restriction of hazardous substances)

Name of the person authorized to compile the technical

Katja Langer

Bannewitz, 2025-09-08

Signature:

A handwritten signature in black ink, appearing to be 'K. Langer', written over a horizontal line.

K. Langer, Managing Director

## **2 General Information**

### **2.1 Storage of the User Manual**

This user manual enables the safe and efficient use of the P603-1/750 set. It must be kept close at hand and accessible to the user.

### **2.2 Reading and Understanding the User Manual**

Read the user manual carefully, observe the safety information (**Chapter 5**) and follow the instructions given in this manual before putting the device into service.

### **2.3 Local Safety and Accident Prevention Regulations**

The local accident prevention and general safety regulations also apply to ensure that the P603-1/750 set is used for its intended purpose.

### **2.4 Images**

Figures have been included in this user manual to assist the reader's understanding but may differ from the device's actual version.

### **2.5 Limitation of Liability**

In the following cases, Langer EMV-Technik GmbH can assume no liability for damage to property and personal injury if:

- The information given in this user manual has not been observed.
- P603-1/P750 set was operated by staff not qualified in the field of EMC.
- P603-1/P750 set was subjected to unauthorized modifications or technical changes.
- P603-1/P750 set was not used according to its intended purpose.
- Spare parts or accessories were used that had not been approved by Langer EMV-Technik GmbH.

The actual scope of delivery may deviate from the illustrations and texts in this user manual due to the customization of orders or due to technical changes and innovations.

### **2.6 Errors and Omissions**

The information in this manual has been carefully checked and is believed to be accurate; however, the Langer EMV-Technik GmbH assumes no responsibility for any clerical, typographical, or proofreading errors, or omissions.

### **2.7 Copyright**

The content of this user manual is protected by copyright law and may only be used in connection with the P603-1/750 set. This user manual may not be used for any other purpose without the prior written approval of Langer EMV-Technik GmbH.

### 3 Scope of Delivery

Item	Designation	Type	Quantity
1	RF current probe 1 ohm	<b>P603-1</b>	1
2	RF voltage probe 150 ohm	<b>P750</b>	1
3	ChipScan-ESA software	<b>CS-ESA</b>	1
4	Licence dongle	Dongle	1
5	Measurement cable	SMA-SMB 1 m	1
6	Power Supply unit	12 V	1
7	User manual		1
8	Quick guide		1
9	System case	P603 / P750 case	1

**Important:** The scope of delivery may deviate depending on the respective order.

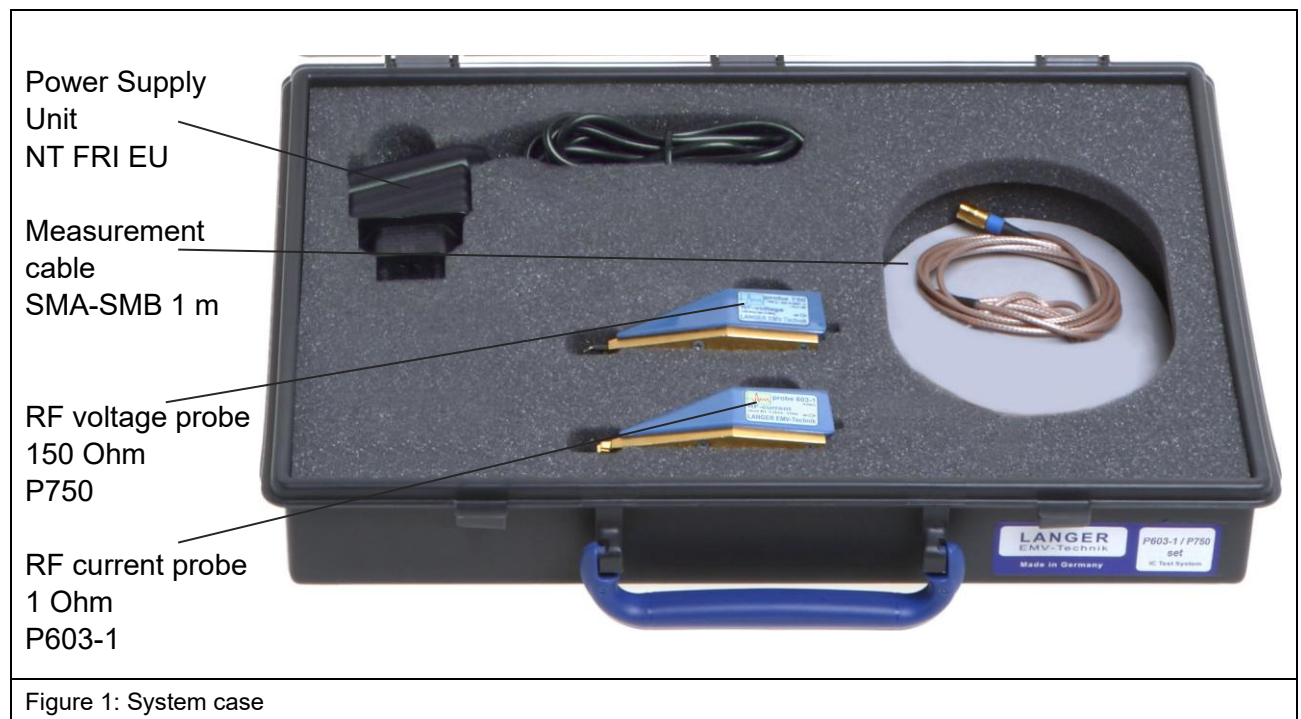

## 4 Technical Parameters

### 4.1 P603-1 Probe

<b>Shunt</b>	1 $\Omega$
<b>Transfer factor <math>V_{out} / V_{in}</math></b>	-6 dB
<b>Current correction factor R</b>	-6 dB $\Omega$
<b>Max. power dissipation shunt</b>	2.5 W
<b>Inductance of RF input</b>	1 nH
<b>RF measuring output</b>	50 $\Omega$ (SMB)
<b>Frequency range</b>	0.2 kHz – 3 GHz

Table 1: P603-1 technical parameters

Current correction factor R [dB $\Omega$ ]

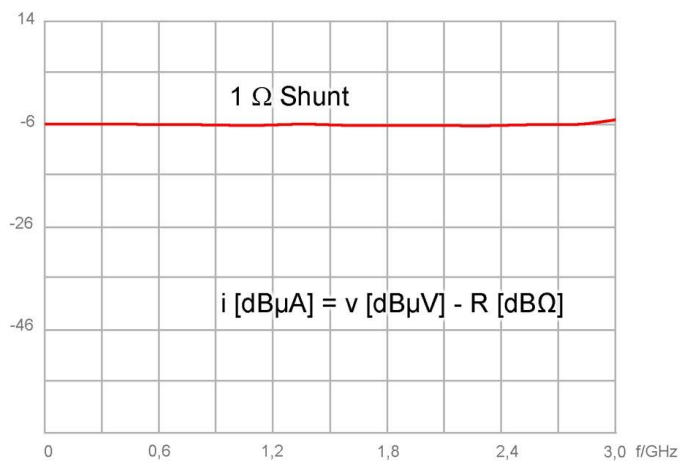

Figure 2: P603-1 characteristic

## 4.2 P750 Probe

<b>Transfer factor <math>V_{out} / V_{in}</math></b>	-15.2 dB
<b>Frequency range</b>	150 kHz to 3 GHz
<b>Input resistance</b>	150 $\Omega$
<b>Max. input voltage for RF</b>	3.5 V
<b>Max. input voltage for DC</b>	50 V
<b>RF measuring output</b>	50 $\Omega$ (SMB)

Table 2: P750 technical parameters

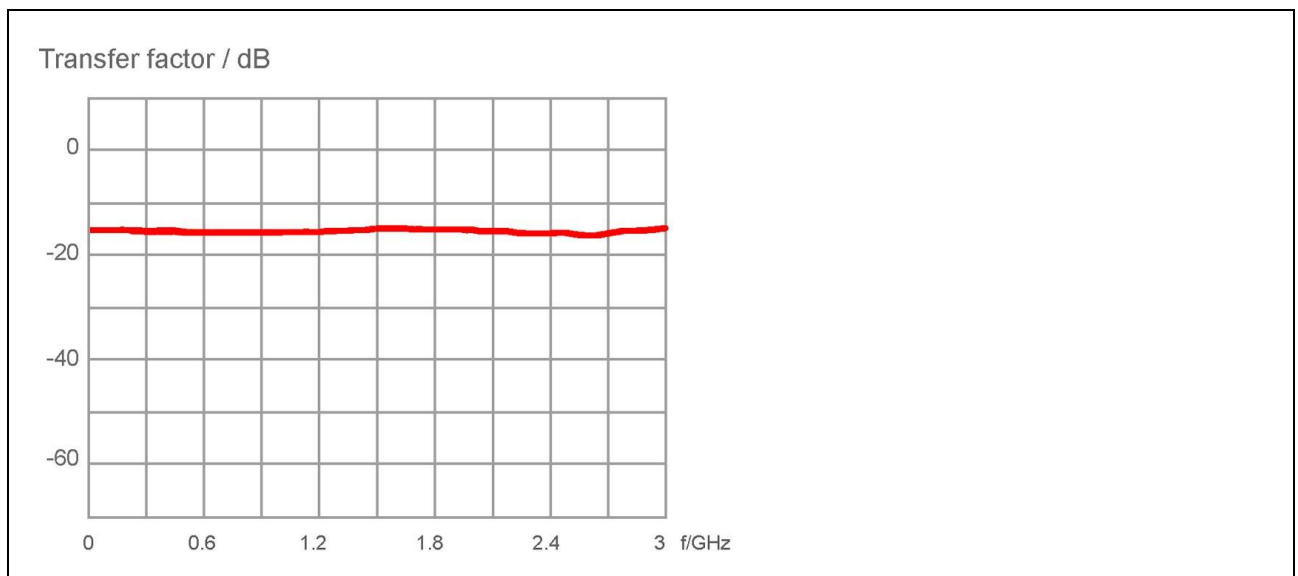





Figure 3: P750 characteristic

## 5 Safety

### 5.1 Labels and Signs

 <p>General warning sign</p>	 <p>Warning; Electricity</p>	 <p>Prohibition sign; No access for people with active implanted cardiac devices.</p>
<p>Table 3: Safety signs</p>		

Safety instructions in this user manual are marked by symbols (**Table 3**). Observe the safety precautions and act cautiously to avoid accidents as well as personal and material damages.

### 5.2 Intended Use

The **P603-1** and **P750** probes have been developed to measure conducted emissions from integrated circuits (ICs) with direct 10 Ohm/150 Ohm coupling. The probes can be used to perform measurements on ICs according to IEC 61967-4 (**Figure 4**). The **P603-1** probe corresponds to the 1 Ohm RF current probe head.

The **P750** probe corresponds to the impedance matching network according to IEC 61000-4-6. It has an input impedance of 150 Ohm.

The **P750** probe can be used to perform RF voltage measurements and the **P603-1** probe can be used for RF current measurements on IC pins.

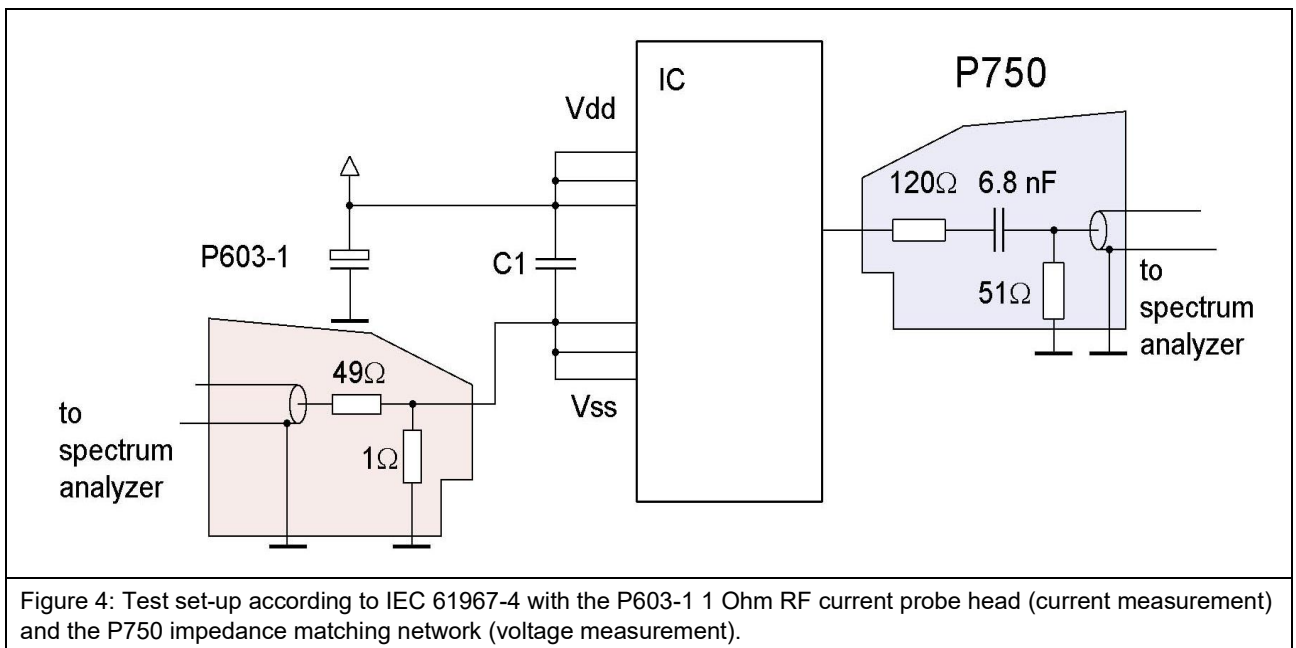

Figure 4: Test set-up according to IEC 61967-4 with the P603-1 1 Ohm RF current probe head (current measurement) and the P750 impedance matching network (voltage measurement).

The **P603-1** and **P750** probe can also be used for the following measurement tasks:

1. Current measurement (P603-1) on concatenated Vdd pins (with external capacity), **Figure 5**
2. Current measurement (P603-1) on a single Vss pin, **Figure 6**
3. Current measurement (P603-1) on a single Vdd pin (with external capacity), **Figure 7**
4. Voltage measurement (P750) on a signal pin while this is in operation, **Figure 8**
5. Current measurement (P603-1) on a signal pin while this is in operation (with external capacity), **Figure 9**
6. Voltage measurement (P750) on a Vdd or Vss pin, **Figure 10**

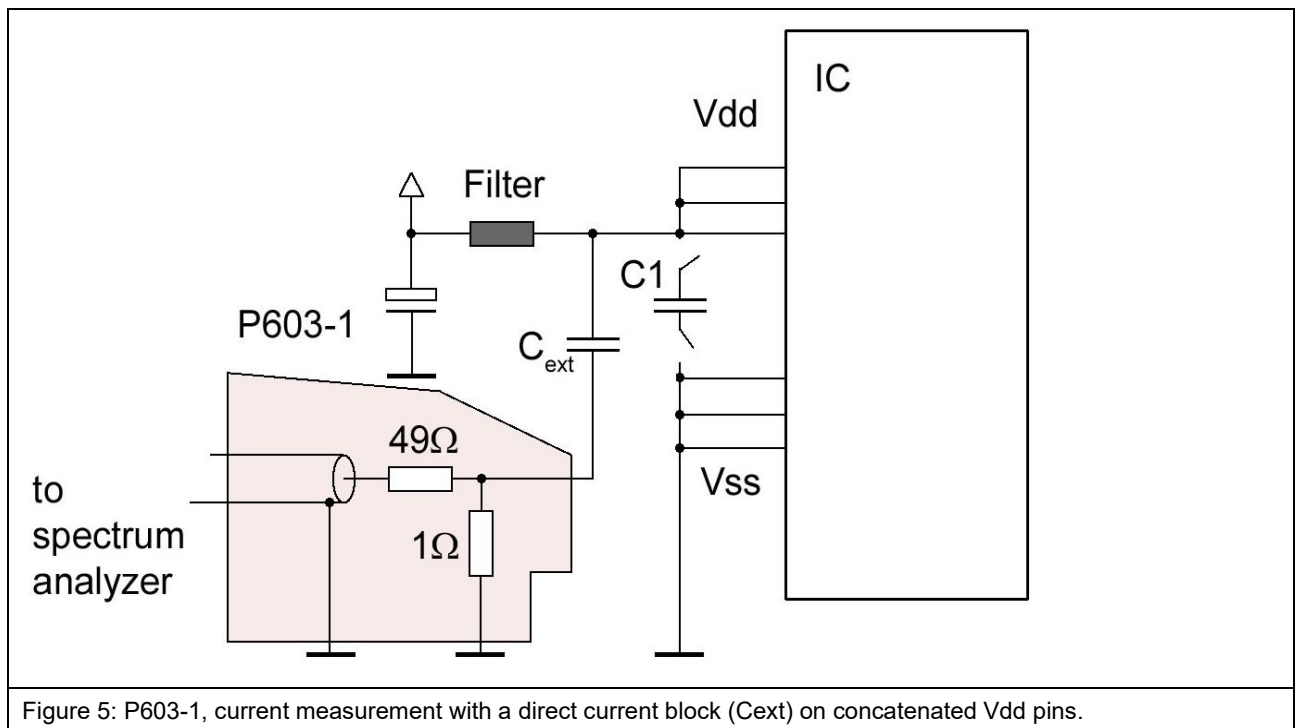

Figure 5: P603-1, current measurement with a direct current block (C<sub>ext</sub>) on concatenated Vdd pins.

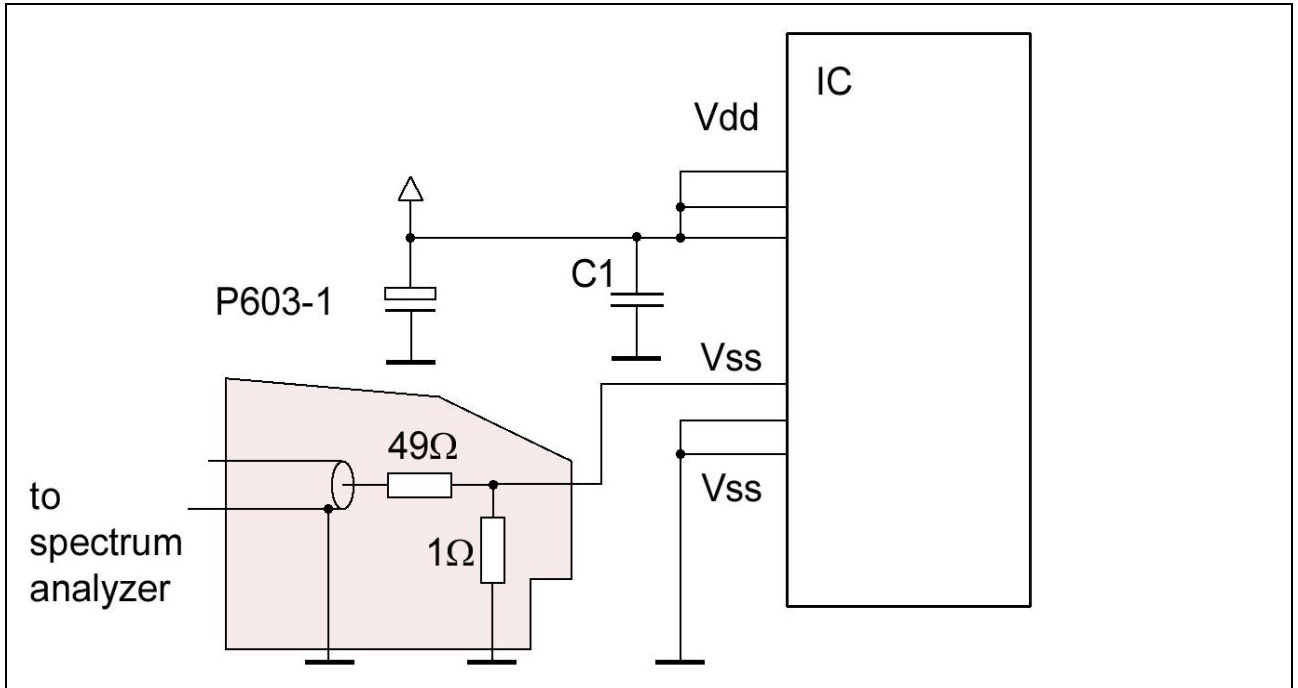

Figure 6: P603-1, current measurement on a single Vss pin.

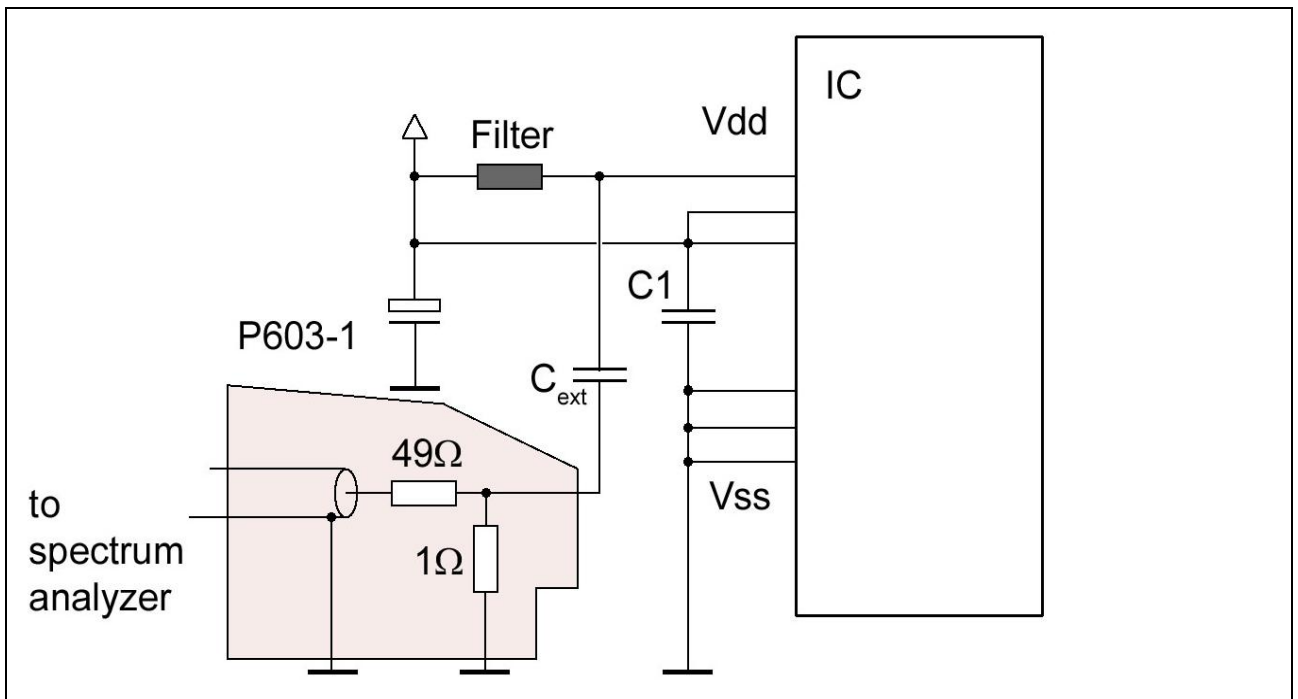

Figure 7: P603-1, current measurement on a single Vdd pin with external DC-decoupling.

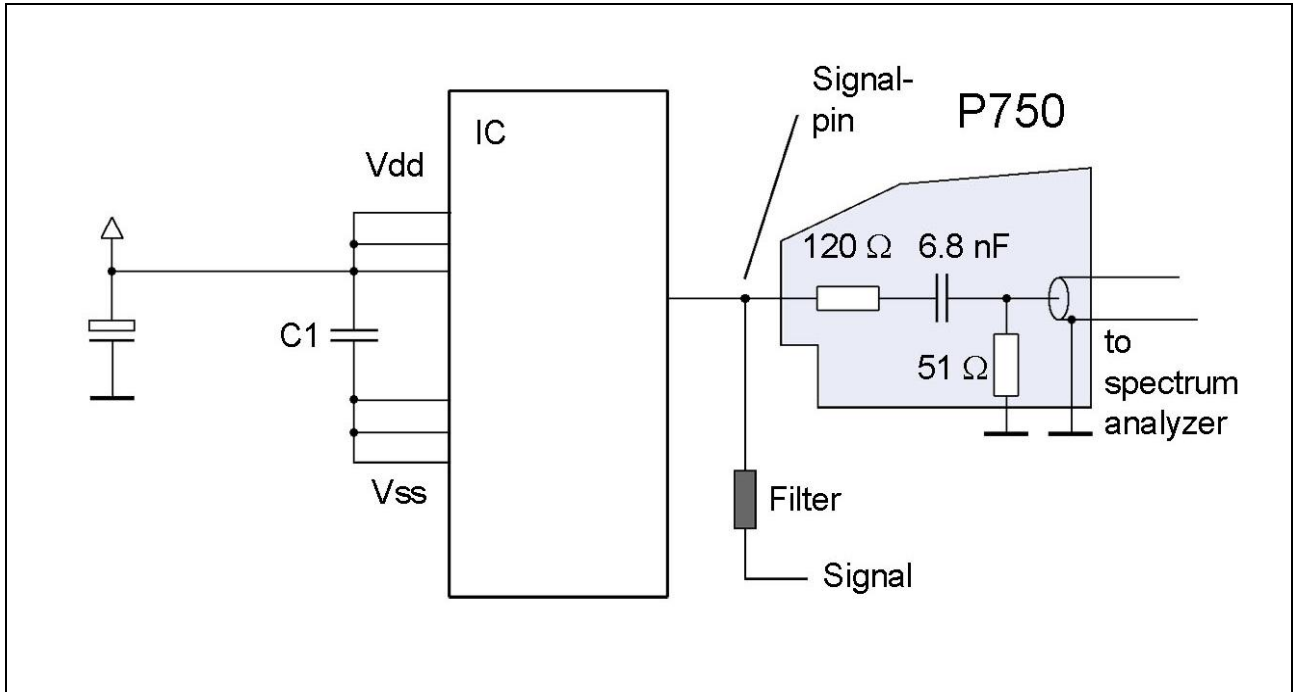

Figure 8: P750, voltage measurement on a signal pin while this is in operation.

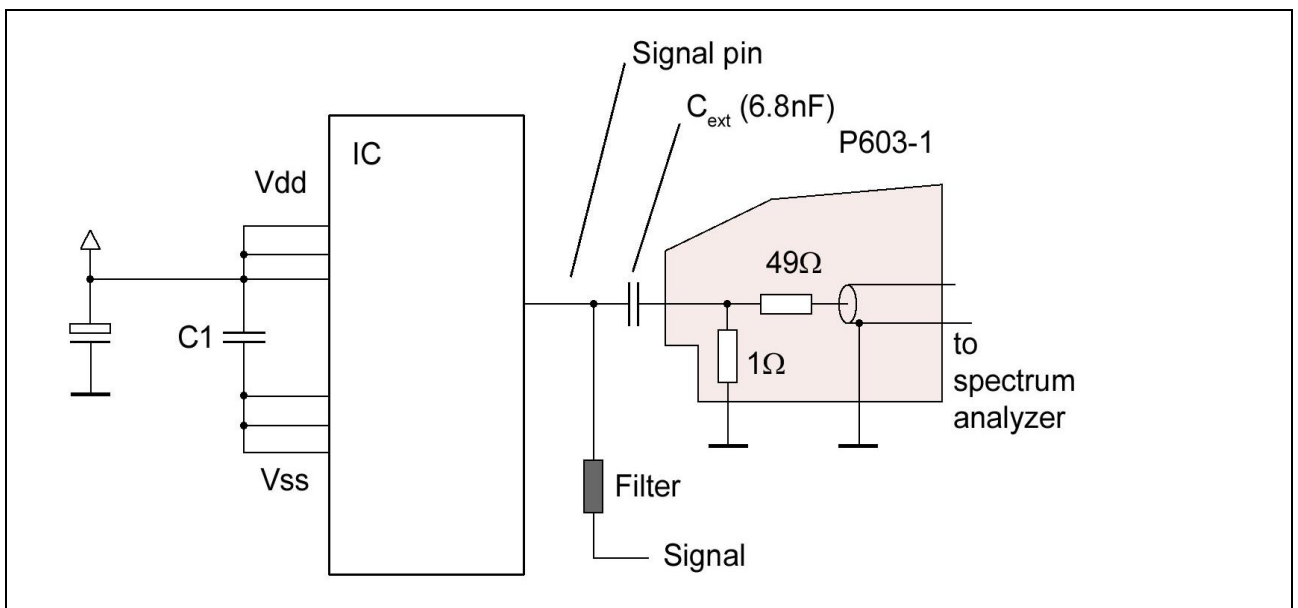
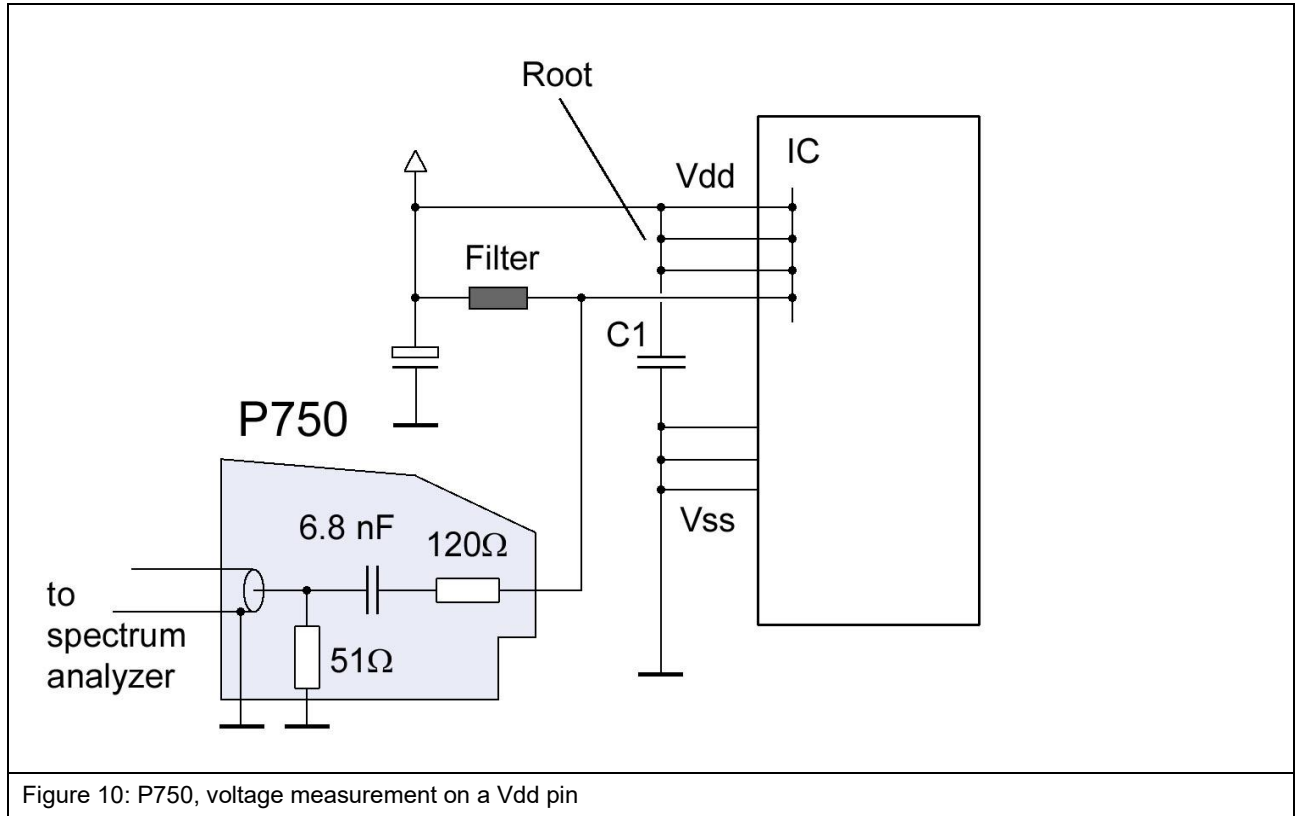

Figure 9: P603-1, current measurement on a signal pin while this is in operation.



### 5.3 Reasonably foreseeable Misuse



**Danger resulting from misuse!**

**Misuse of the P603-1/750 set can lead to dangerous situations!**

- Use of the product outside of the given specifications.
- Modification or changing of the product without consent of Langer EMV-Technik GmbH.
- Operating the product with a technical fault.

### 5.4 Staff Requisition

Only qualified staff with training, knowledge, and experience in the field of EMC is allowed to operate the P603-1/750 set.

Persons whose ability to perform is influenced or impaired by alcohol, drugs, or pharmaceuticals, are not allowed to operate the P603-1/750 set.

Certain functions may only be carried out by qualified personnel of Langer EMV-Technik GmbH.

## 5.5 Safety Instructions

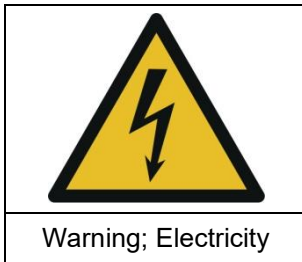

**Danger resulting from Electricity!**

**Risk of injury by electrocution!**

Only connect the high-voltage cable to the P603-1/P750 probe before operation.

Don't touch the probe tip of a P603-1/P750 probe while it is in operation.

- If insulation is damaged, the power supply has to be disconnected immediately.
- Replace damaged parts with undamaged parts before operation. Contact Langer EMV-Technik GmbH for proper replacements.
- Protect live parts from moisture to avoid short circuits.

Never leave a Langer EMV-Technik GmbH product unattended while this is in operation.

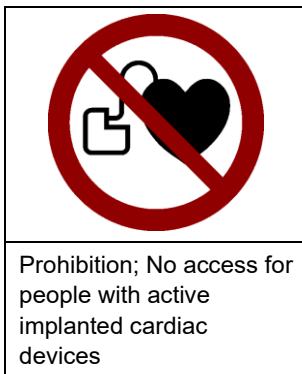

**Danger resulting from electromagnetic fields!**

**Risk of affecting a cardiac device!**

Persons with a cardiac device, such as a pacemaker, are not allowed to work on or approach the P603-1/P750 set while it is in operation.

## 6 P603-1 Probe

### 6.1 General Description

The **P603-1** probe is an RF current probe head to measure conducted RF currents on IC pins according to IEC 61967-4. The measurement is performed with a 1 Ohm shunt.

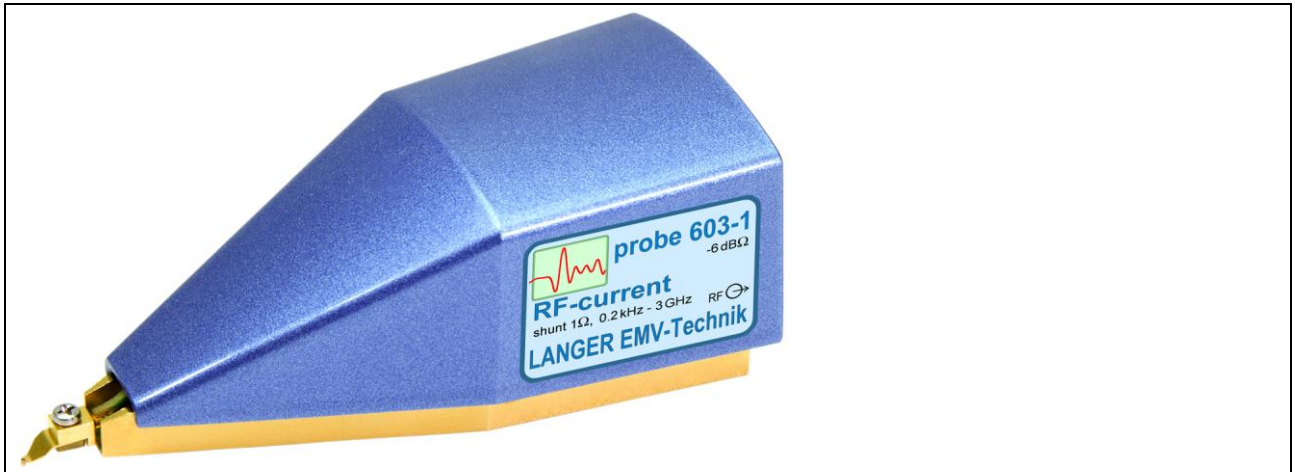

Figure 11: P603-1 probe

### 6.2 Design and Function of the P603-1 Probe

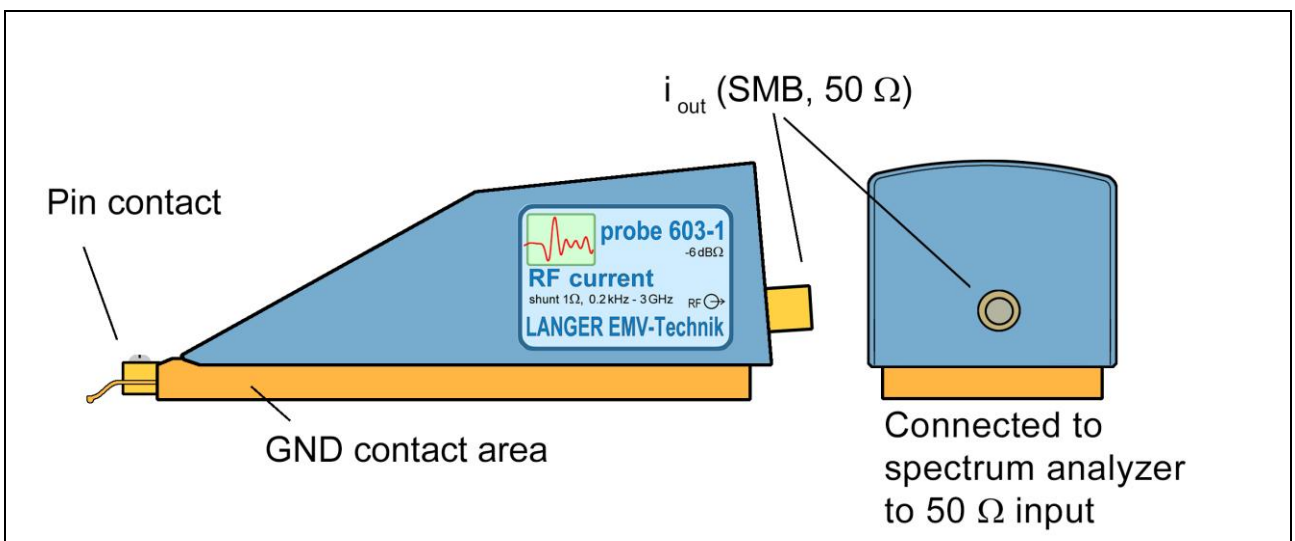

Figure 12: Design of the P603-1 probe

The **P603-1** probe contains a 1 Ohm current probe head (IEC 61967-4). The input of the current probe head is connected to the probe's pin contact (**Figure 12**). The output of the current probe head is connected to the 50 Ohm SMB port at the rear end of the probe.

A cable is used to connect the probe's output to a measuring instrument such as a spectrum analyzer. The voltage measured is equivalent to the current measured.

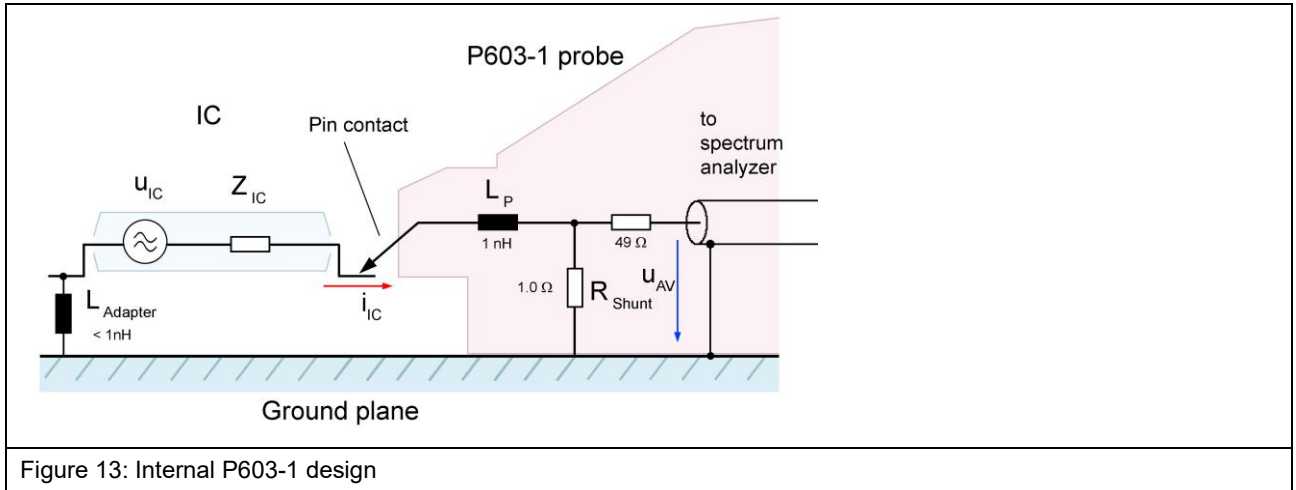

Figure 13: Internal P603-1 design

**Figure 13** shows the equivalent circuit diagram of the **P603-1** probe. The current probe head comprises a 1 Ohm shunt and a 49 Ohm matching resistor. An additional capacitor  $C_{ext}$  can be inserted between the test IC and the probe to reduce the stress on the signal pins caused by the 1 Ohm shunt. The **P603-1** current probe head has an inductance  $L_P$  of 1 nH in the line from the tip of the probe contact to the shunt. This value and the associated measurement error are much smaller than the value achieved with the set-up according to IEC 61967-4. The pin contact of the probe has to be brought into contact with the respective test IC pin to perform the measurement. Please refer to the “ICE1 user manual”<sup>1</sup> and “Guideline IC EFT immunity”<sup>2</sup>.

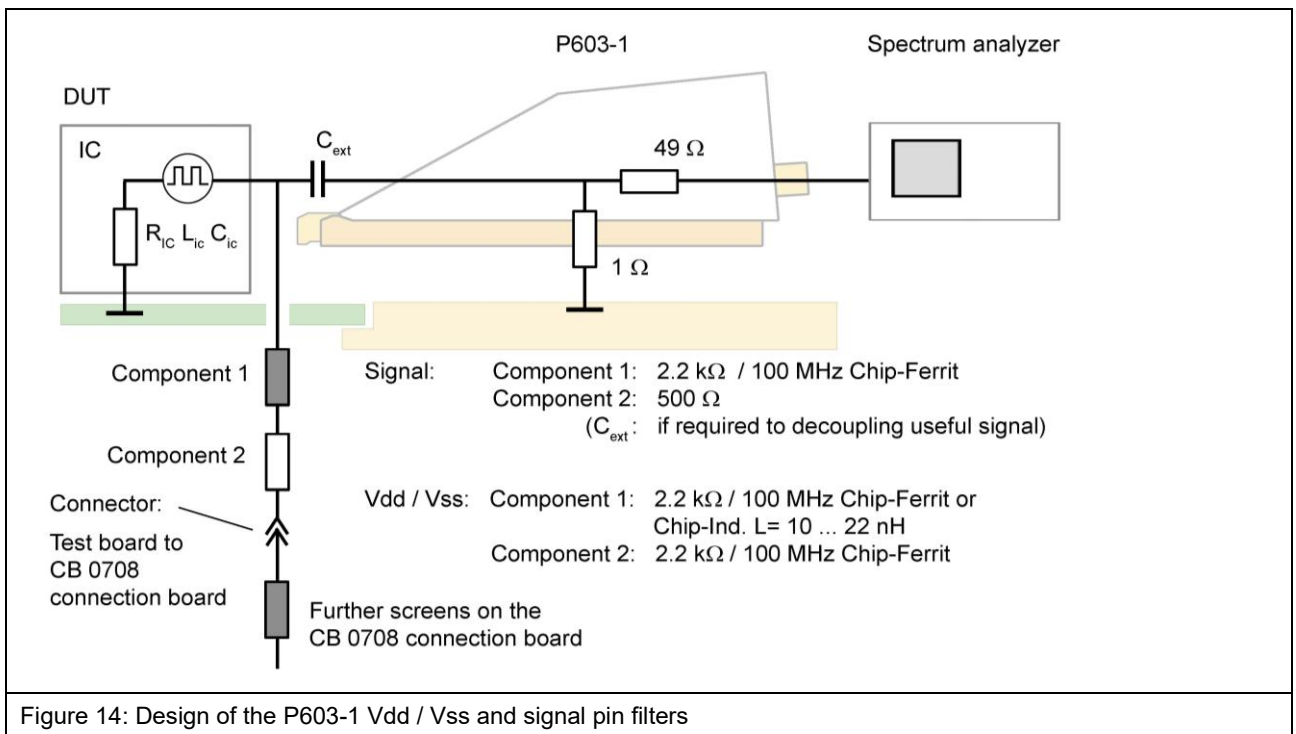

Figure 14: Design of the P603-1 Vdd / Vss and signal pin filters

**Figure 14** shows the design of the Vdd / Vss and signal pin filters which are located on the bottom of the test board. Please refer to the “IC test instructions”<sup>3</sup> for a guideline IC EFT immunity on how to set up a test board.

<sup>1</sup> mail@langer-emv.de

<sup>2</sup> mail@langer-emv.de

<sup>3</sup> mail@langer-emv.de

## 7 P750 Probe

### 7.1 General Description

The **P750** probe is a matching network to measure conducted RF voltages on IC pins according to IEC 61967-4.

The **P750** has been designed for measurements on supply (Vdd / Vss) and signal pins. The measurement is performed with a 150 Ohm voltage divider.



Figure 15: P750 probe

### 7.2 Design and Function of the P750 Probe

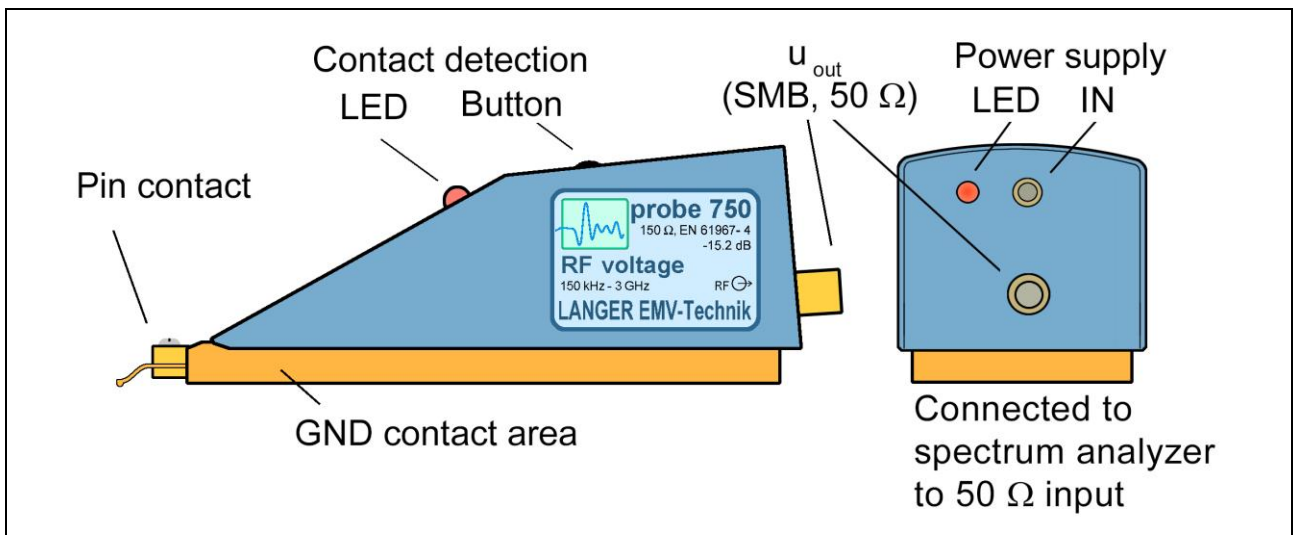

Figure 16: Design of the P750 probe

The **P750** probe contains a 150 Ohm matching network (IEC 61967-4). The input of the matching network is connected to the probe's pin contact (**Figure 16**). The output of the matching network is connected to the 50 Ohm SMB port at the rear end of the probe. A cable is used to connect the probe's output to a measuring instrument such as a spectrum analyzer.

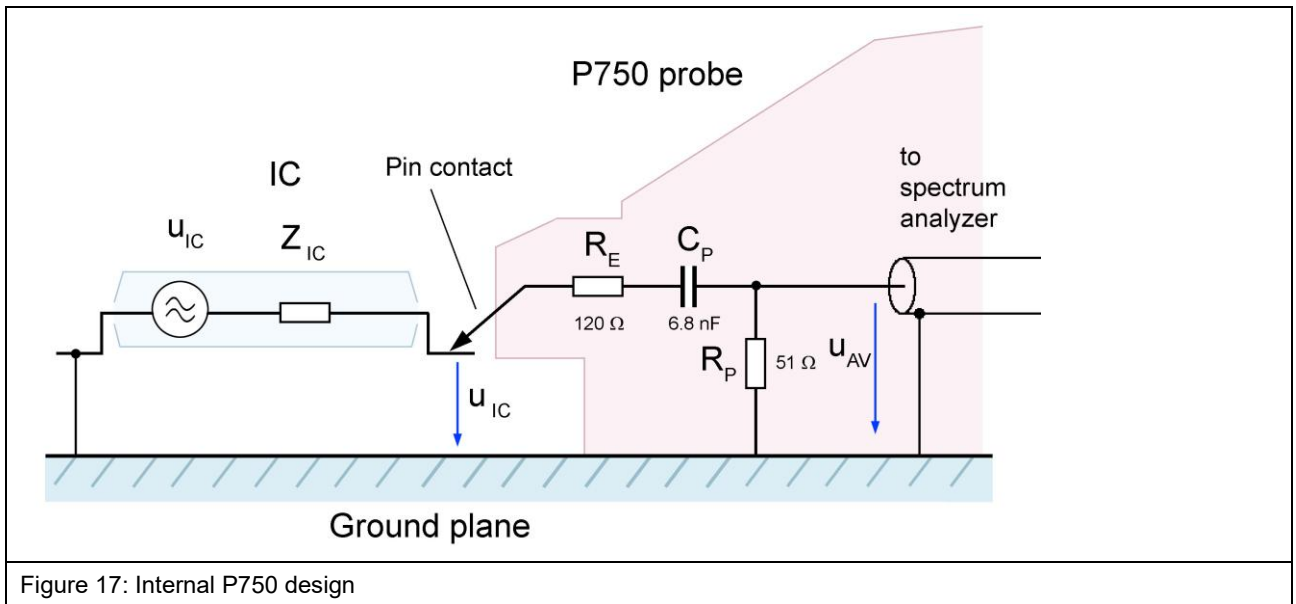

Figure 17: Internal P750 design

**Figure 17** shows the equivalent circuit diagram of the **P750** probe. The matching network comprises a 120 Ohm – 51 Ohm voltage divider and a 6.8 nF coupling capacitor. The pin contact of the probe has to be brought into contact with the respective test IC pin to perform the measurement. Please refer to the “ICE1 user manual” and “Guideline IC EFT immunity”<sup>1</sup>.

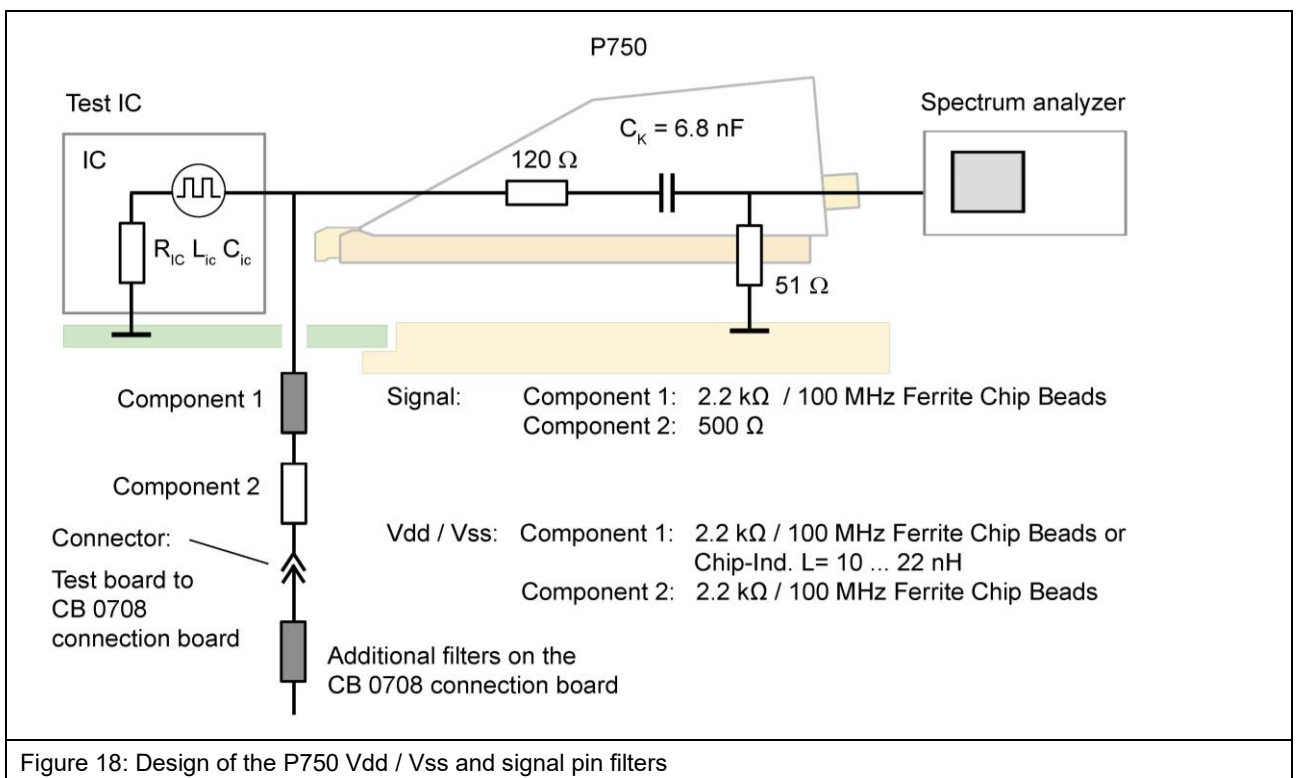

Figure 18: Design of the P750 Vdd / Vss and signal pin filters

**Figure 18** shows the design of the Vdd / Vss and signal pin filters which are located on the bottom of the test board. Please refer to the “IC test instructions” for a guideline IC EFT immunity on how to set up a test board.

<sup>1</sup> mail@langer-emv.de

## 8 Contact Detection

The contact detection is used to detect a galvanic connection of the probe tip with a IC pin automatically.

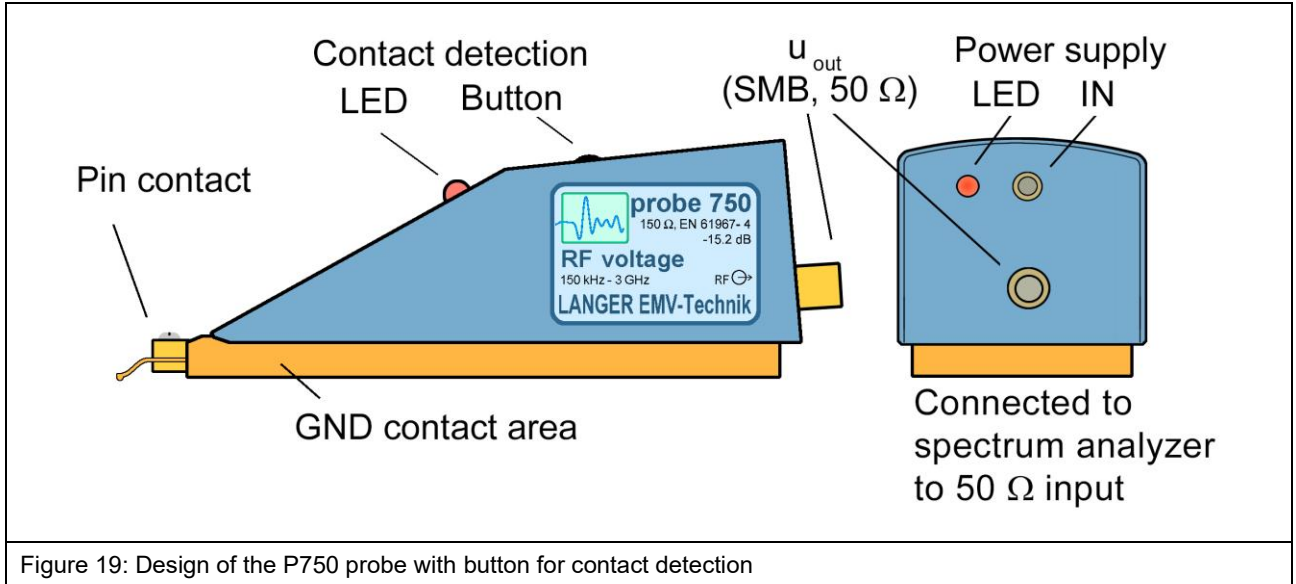

Figure 19: Design of the P750 probe with button for contact detection

The probe tip is forward biased to a potential of -5 V by pushing the button for contact detection. If there is a galvanic connection between the probe tip and the IC-pin, the voltage level on the probe tip decreases due to the structure of the internal IC circuit. The voltage drop is detected, and the contact is indicated by the LED at the upper section of the probe housing.

**NOTE:** Not connected Pins (NC) can't be detected.

## 9 Measurement Set-up

### 9.1 Performing the Measurement

**Figure 20** shows the measurement set-up to measure conducted emissions from integrated circuits (ICs). The test IC is mounted on the test board. The test board is inserted into the corresponding ground adapter such as GNDA 02<sup>1</sup>. The signal and supply connections to the test IC are established through a plug connector on the test board. The test IC is supplied via the test board and controlled via the connection board. The associated Connection Board Control software can be used to control and monitor the test IC from a PC.

The P603-1 or P750 probe is placed on the GND 25<sup>2</sup> ground plane with the GNDA 02 ground adapter. The respective pin of the test IC can be contacted with the pin contact by moving the probe manually. The microscope camera (**Figure 20**) optically detects if and when contact is made. The camera's image is displayed on the PC monitor via the ChipScan-ESA software (**Figure 22**). The video image on the PC monitor enables the user to assess the connection to the respective IC pin. The spectrum analyzer displays the RF signal that occurs if and when contact is made. The input of the spectrum analyzer is connected to the SMB output of the probe via an SMA-SMB 1 m RF cable.

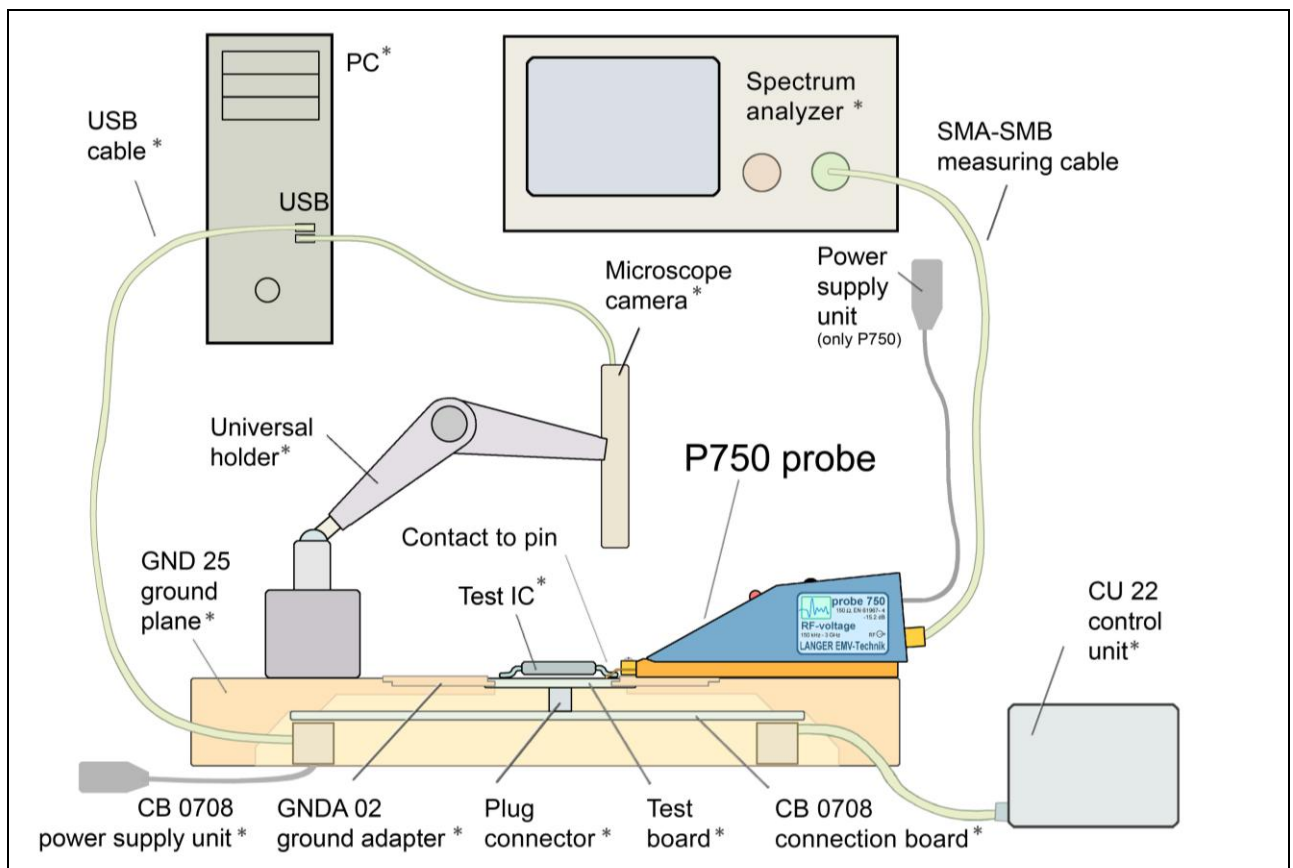

Figure 20: Measurement set-up to measure conducted emissions from integrated circuits (ICs) with the IC test system.

Components marked with an asterisk (\*) are not included in the scope of delivery of the "P603-1 / P750 set.

<sup>1</sup> The GNDA 02 ground adapter is included in the ICE1 IC test environment. [www.langer-emv.de](http://www.langer-emv.de)

<sup>2</sup> The GND 25 ground plane is included in the ICE1 IC test environment. [www.langer-emv.de](http://www.langer-emv.de)

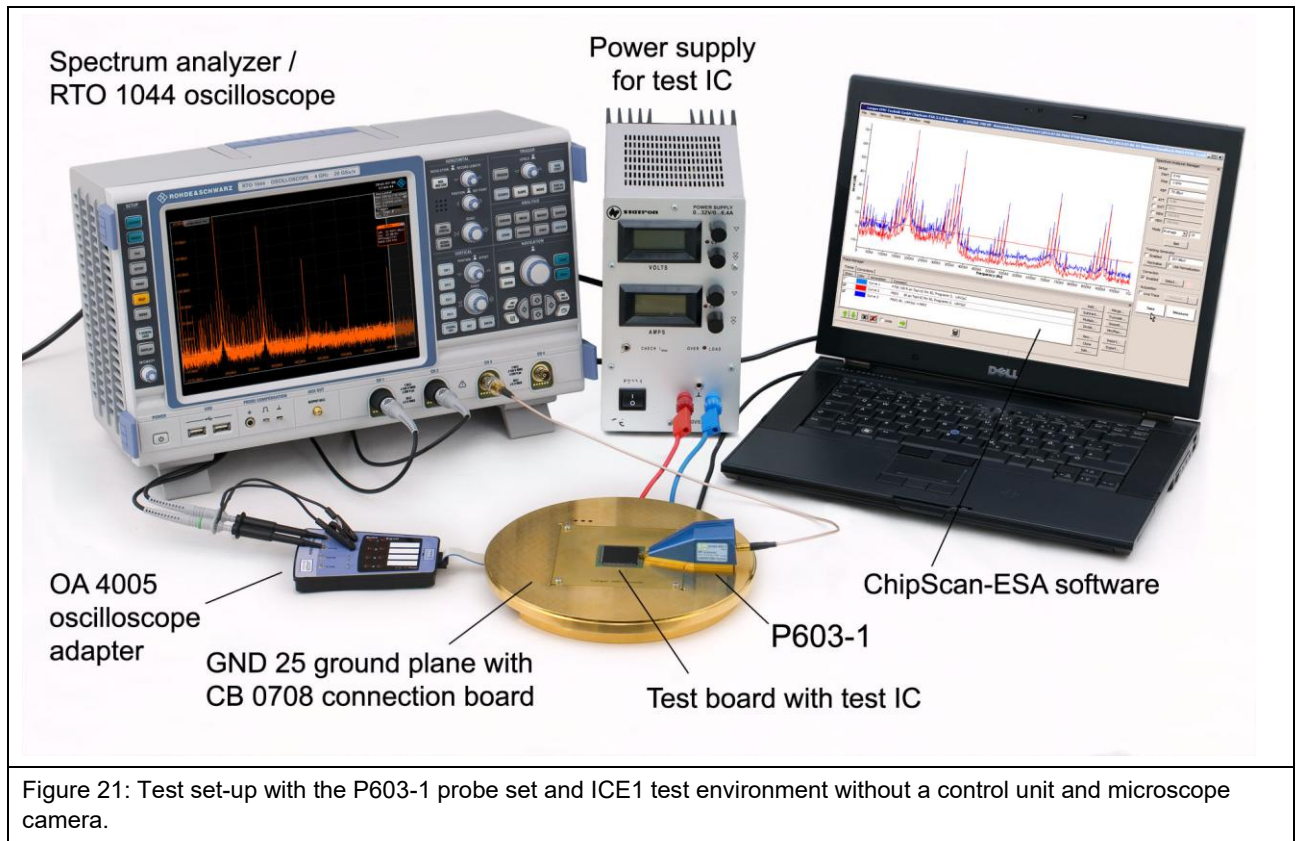

Figure 21: Test set-up with the P603-1 probe set and ICE1 test environment without a control unit and microscope camera.

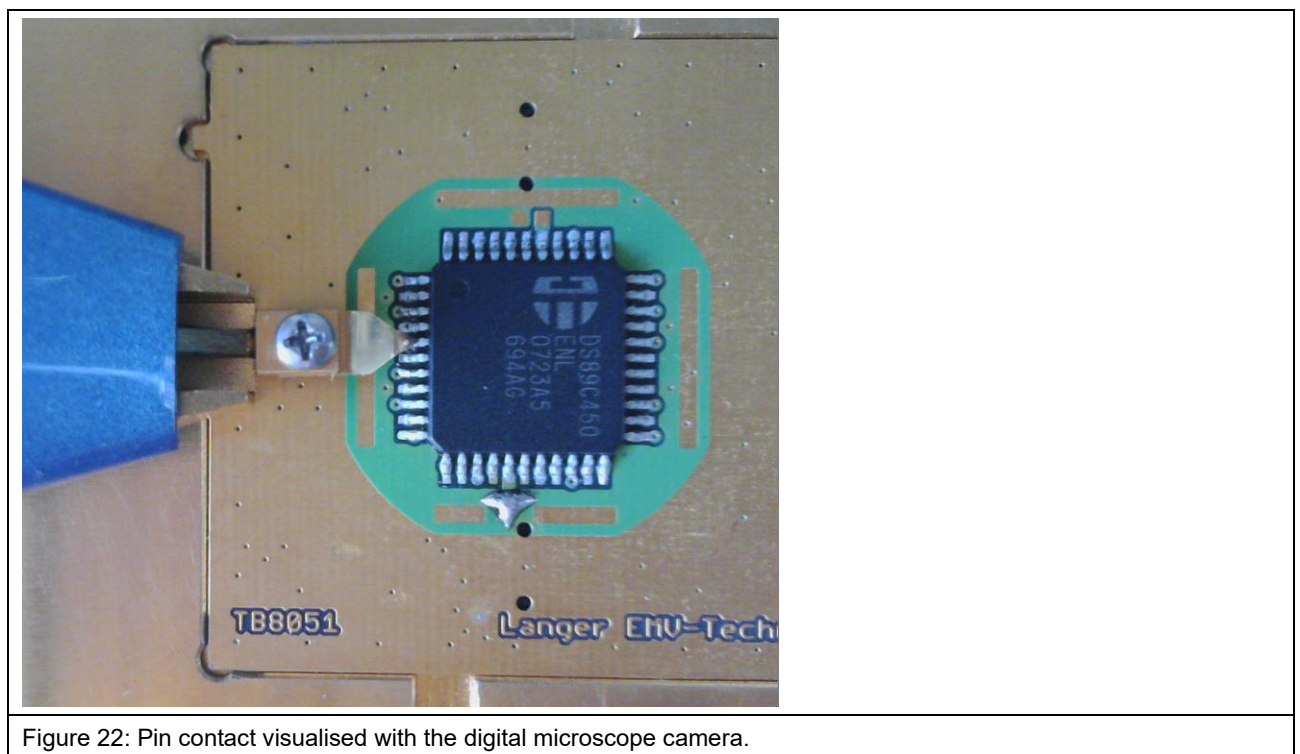

Figure 22: Pin contact visualised with the digital microscope camera.

The test IC is soldered to the test board<sup>1</sup> (**Figure 23**). The P603-1 and P750 probes can be moved freely on the GND 25 ground plane or GNDA ground adapter<sup>2</sup> (**Figure 23**). Unlike the measurement set-up according to IEC 61967-4, this set-up ensures that the P603-1 or P750 probe's pin contact can reach and contact each IC pin. The probes are fixed on the ground plane with magnets. Filter elements and bridges are located on the underside (bottom) of the test board to prepare the measurement set-up for contact with the probe (**Figure 25**).

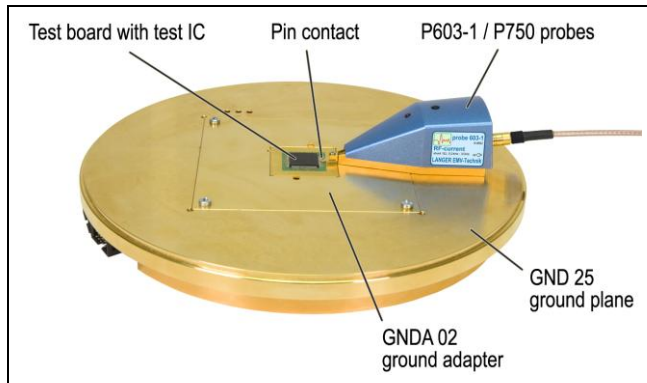

Figure 23: Measurement set-up according to the 1 Ohm method with P603-1 and the 150 Ohm method with P750.

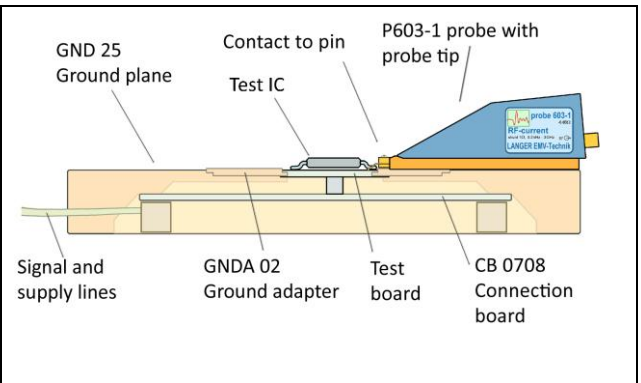

Figure 24: Sectional view of the measurement set-up.

The same test board is used for all measurement methods (1 Ohm, 150 Ohm). Bridges are provided to the Vdd / Vss root at the Vdd / Vss pins in the initial state. The associated bridge to the root is removed and the corresponding filter becomes active if a Vdd / Vss pin is measured.

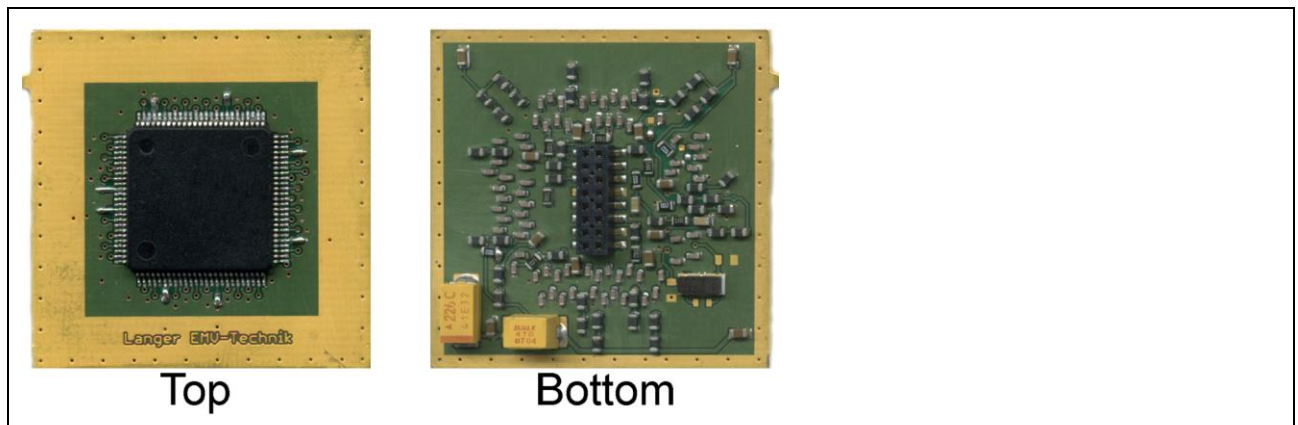

Figure 25: Design of the test board; top with Vss bridges, bottom with back-up capacitors, filters and quartz crystal oscillator circuit.

<sup>1</sup> The test board is described in the " guideline IC EFT immunity ", mail@langer-emv.de

<sup>2</sup> GNDA 02 ground adapter and GND 25 ground plane are included in the ICE1 IC test environment. [www.langer-emv.de](http://www.langer-emv.de)

## 10 Using the ChipScan-ESA Software

The spectrum analyzer is sought automatically with "Devices/Devices Manager/Detected Devices" by choosing the respective interface and if it is properly connected to the PC (**Figure 27**).

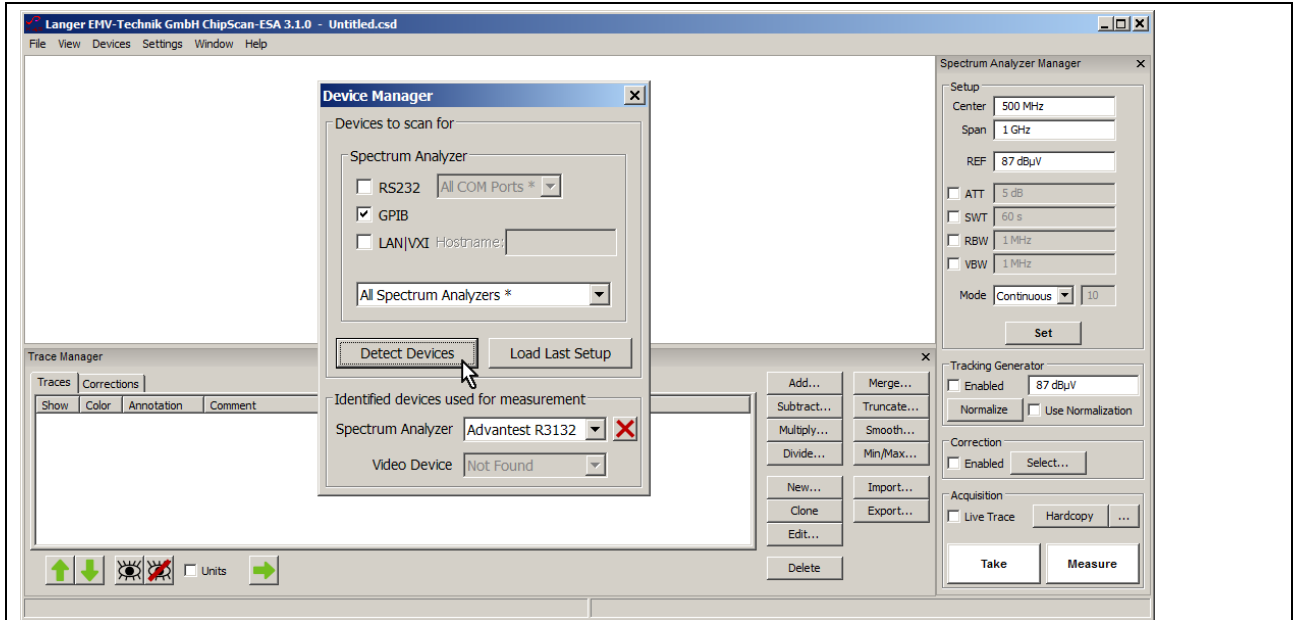

Figure 26: Connecting the spectrum analyzer to the PC.

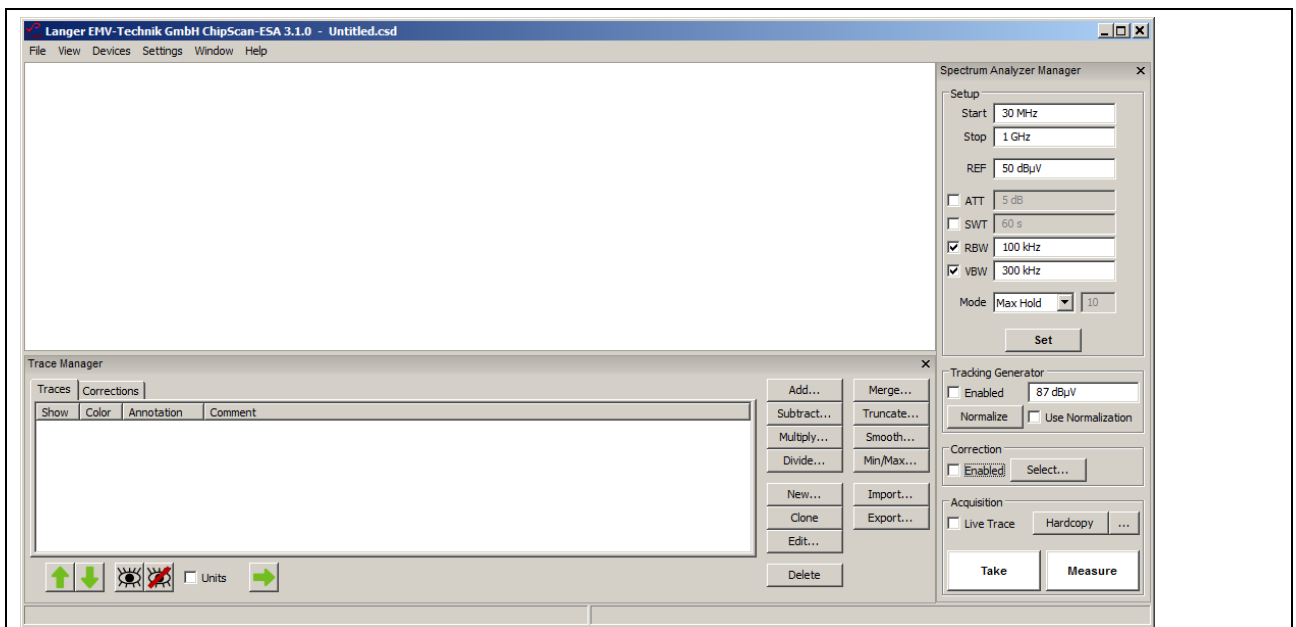

Figure 27: Main settings of the spectrum analyzer in the "Spectrum Analyzer Manager" (right side).

The main settings of the spectrum analyzer have to be defined in the Spectrum Analyzer Manager (**Figure 27**). The correction curve K603-1 or K750 has to be used to correct the frequency response of  $U_{AV}(\omega)$  measured with the P603-1 or P750 probe.  $U_{AV}(\omega)$  can be converted to  $I_{IC}(\omega)$  and  $U_{IC}(\omega)$  automatically in the Correction area of the Spectrum Analyzer Manager. The correction curve K603-1 or K750 has to be used for this purpose.

Mathematical functions can also be used (**Figure 28**): division by  $\omega$  in the time domain, for example. This corresponds to a subtraction of  $20 \text{ Log } \omega$  in the logarithmic form.

You can find the correction curve ( $-20 \text{ Log } \omega$ ) in the Corrections list of the Trace Manager.

Click the Select button (mouse cursor ① **Figure 28**) in the Correction area of the Spectrum Analyzer Manager to select the respective correction curve.

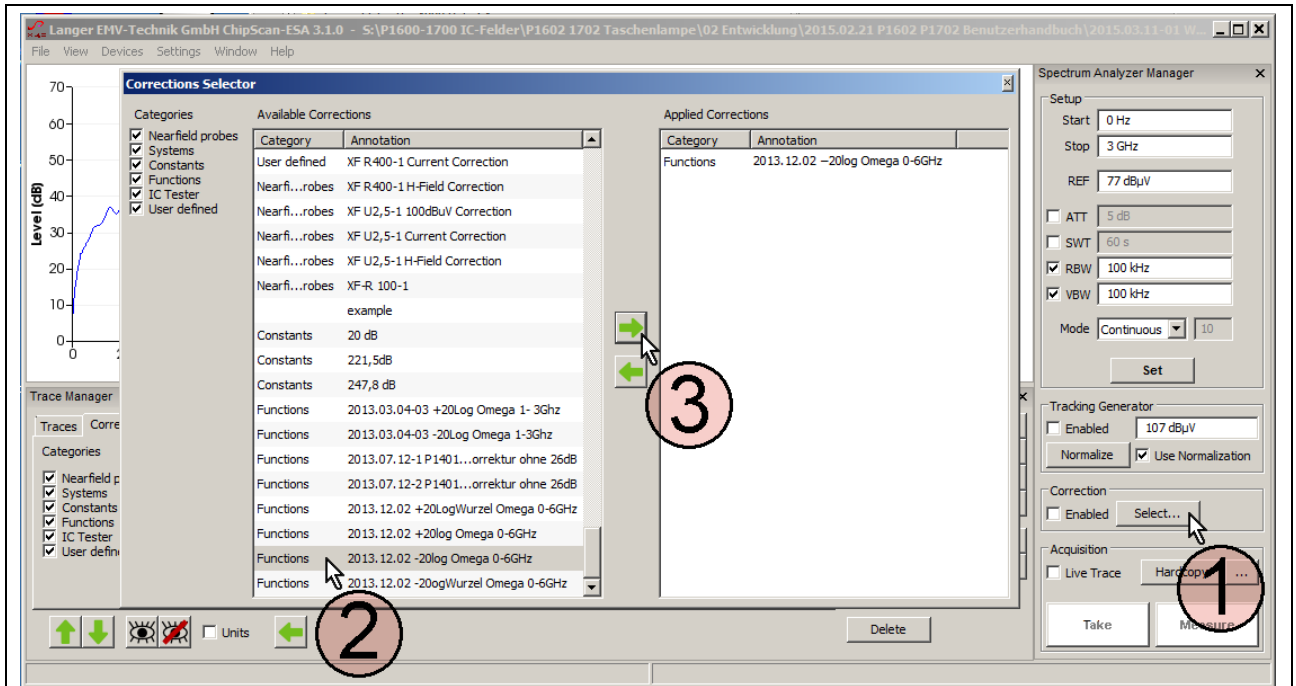

Figure 28: Using mathematical functions by activation in the "Corrections Selector".

The Corrections Selector window opens **Figure 28**. Click and activate the correction curve  $-20 \text{ Log } \omega$  with the mouse cursor ②. Click the "Arrow right" ③ button to move the correction curve to the Applied Corrections list. Other correction factors and correction curves (**Figure 29**) such as K603-1 or K750 can be loaded in the same way or selectively (**Figure 29**).

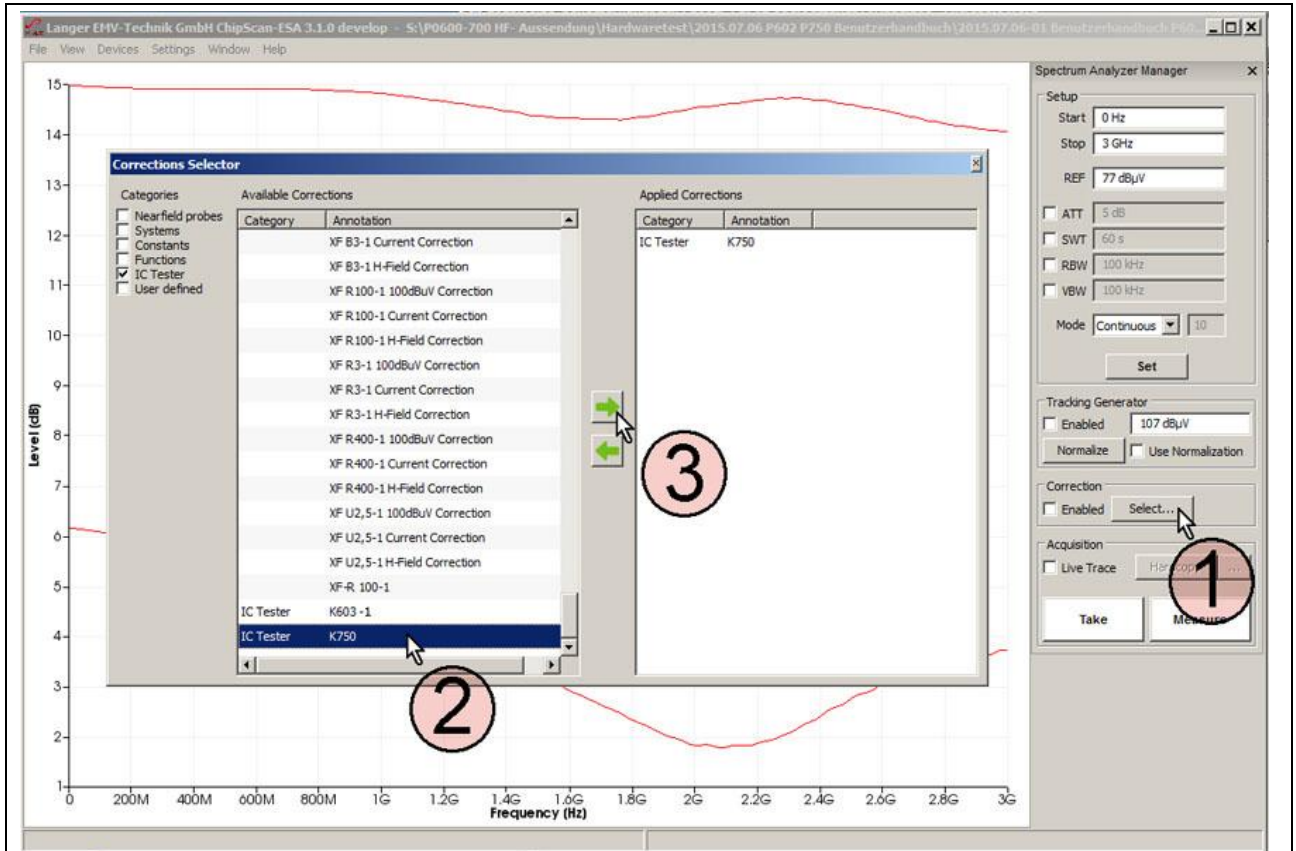

Figure 29: Loading the correction curves K750 to the "Corrections Selector".

The correction curve K603-1 is loaded to the Corrections Selector if the **P603-1** probe is used for the measurement. Activate the "Enabled" box in the Correction area of the Spectrum Analyzer Manager with the mouse cursor ① (**Figure 30**). The field ② flashes if the correction is active **Figure 30**. Click "Take" or "Measure" (mouse cursor ③ **Figure 30**) to transfer the current measurement curve ④  $I_{IC}(\omega)$  from the spectrum analyzer to the PC.

The calculation:  $I_{IC}(\omega) = U_{AV}(\omega) + K603-1$  is automatically performed at the same time. The curve  $I_{IC}(\omega)$  is added to the bottom of the Traces list in the Trace Manager. A measurement log can be kept in the free text field in the Comment column.

Remove the check mark from the "Enabled" box if you only want to measure  $U_{AV}(\omega)$ ; the field ② then stops flashing.

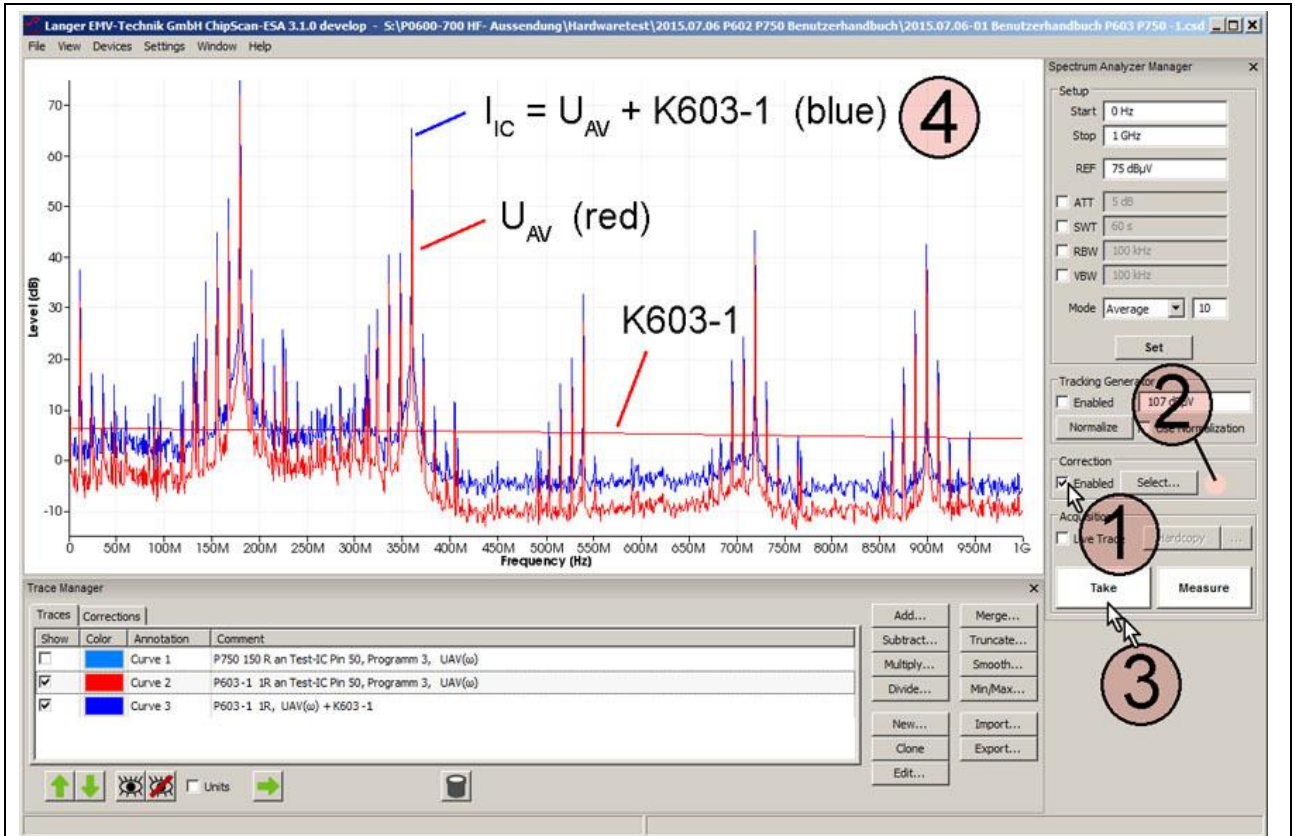

Figure 30: Measurement with the P603-1 RF current probe head using the correction curve K603-1.

The number of the curve is increased automatically (Curve 3) in the Annotation column. The measurement log can be kept in the respective free text field in the Comment column.

The correction can also be made later on if the measurement has been carried out using the **P750** probe without any correction. The correction curve  $U_{IC}(\omega) = U_{AV}(\omega) + K750$  has then to be added.

You can find the correction curve K750 in the Corrections list of the Trace Manager.

Click the Select button (mouse cursor ① **Figure 31**) in the Correction area in the Spectrum Analyzer Manager to select the respective correction curve.

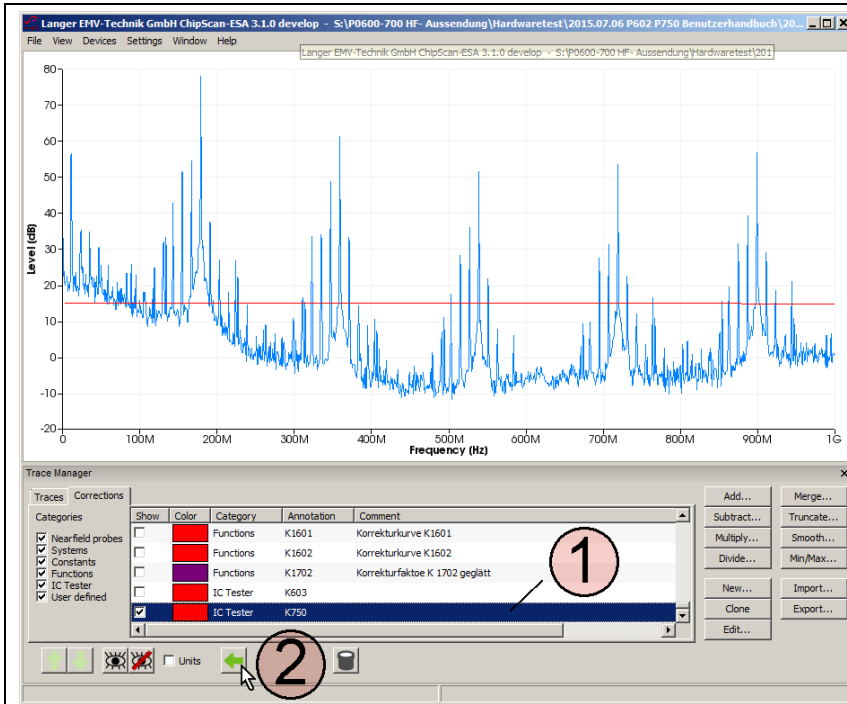

Figure 31: Correction after the measurement; copying K750 from the "Corrections" list to the "Traces" list.

Mark the Curve 1 ( $U_{AV}$ ) curve and the K750 curve in the Traces list **Figure 32** in the Trace Manager with the mouse cursor ①. Open the mathematical operation "Add..." (addition) and activate "Sum up all Plots" (**Figure 32** mouse cursor ③). Click OK ④ to perform the addition  $U_{AV} + K750$ .

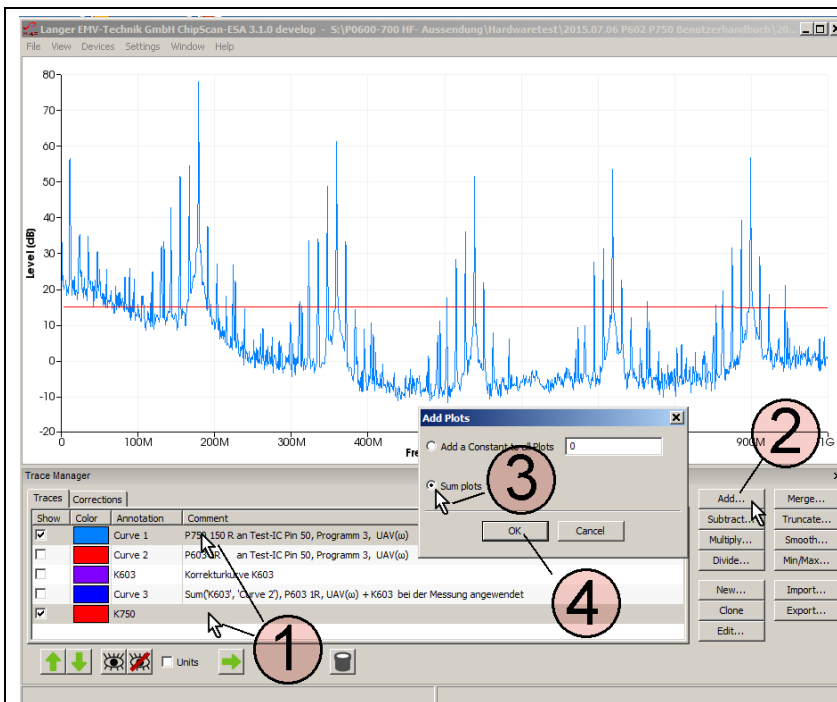

Figure 32: Correction after the measurement; performing the addition  $U_{IC} = U_{AV} + K750$

The calculation creates the entry (① **Figure 33**) at the bottom of the "Traces" list and is displayed as "Curve 5" (② **Figure 33**).

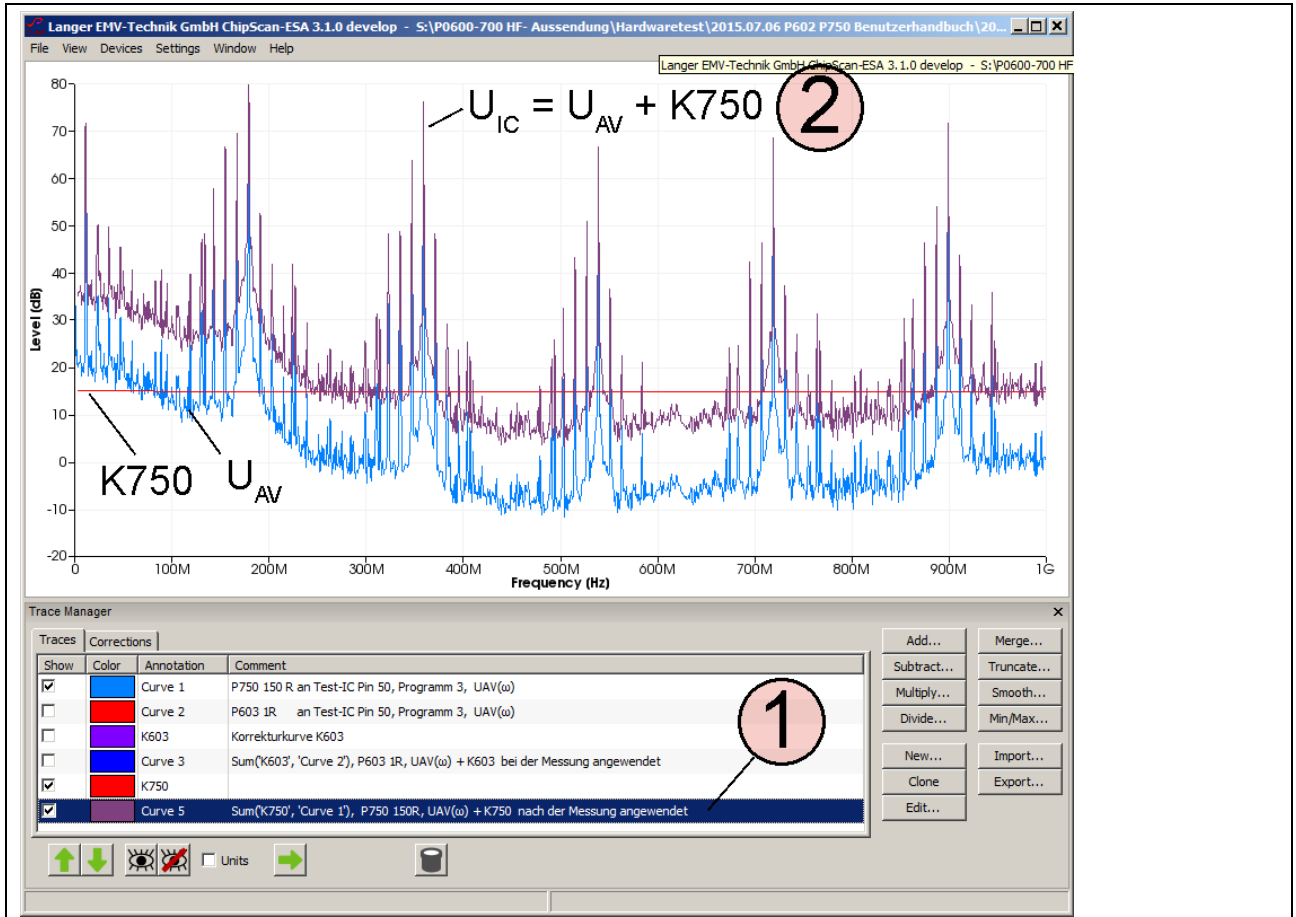

Figure 33: Correction after the measurement; result of the addition  $U_{IC} = U_{AV} + K750$

The manuals for the respective devices and tasks are listed in the following table:

Task	Operating instructions
<ul style="list-style-type: none"> <li>Instructions for the development of the test board</li> <li>Test process</li> </ul>	<p><b>Guideline IC EFT immunity</b> (Langer EMV-Technik GmbH)</p>
<ul style="list-style-type: none"> <li><b>GND 25</b> ground plane</li> <li><b>CB 0708</b> connection board</li> <li><b>OA 4005</b> oscilloscope adapter</li> <li><b>TH 22</b> probe head holder</li> <li>Monitoring and controlling the test IC</li> </ul>	<p><b>ICE1</b> user manual (Langer EMV-Technik GmbH)</p>

Table 4: User manuals for respective devices

## 11 Information on Recycling and Disposal

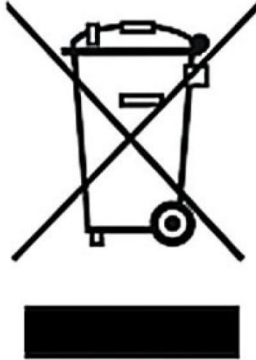

DE 80567526

In accordance with the WEEE Directive 2012/19/EU (Waste of Electrical and Electronic Equipment), the following must be observed:

At the end of its service life, this product should be taken to a suitable disposal facility for recycling and disposal. Do not dispose of with household waste.

## **12 Customer service**

Please contact us if you have any questions, comments or suggestions.

### You can contact us:

Monday – Friday

8:00 Uhr bis 15 Uhr (CET)

### Contact us at:

Address: Langer EMV-Technik GmbH  
Nöthnitzer Hang 31  
01728 Bannewitz  
Germany

Internet: <https://www.langer-emv.com/>

E-mail: [sales@langer-emv.de](mailto:sales@langer-emv.de)

Phone: +49 (0) 351-430093-0

Fax: +49 (0) 351-430093-22

### Calibration

We recommend having the product calibrated every two years by the manufacturer Langer EMV-Technik GmbH or by a certified distributor.

## **13 Warranty**

Langer EMV-Technik GmbH shall remedy all defects attributable to material or manufacturing faults within the statutory warranty period by repairing the product or supplying replacement parts.

**This guarantee is only granted on condition that:**

- the information and instructions in the operating instructions are observed.

**The guarantee expires if:**

- an unauthorized repair is carried out on the product
- the product is modified
- the product is not used as intended

This document may not be copied, reproduced or processed, duplicated or distributed using electronic systems, either in whole or in part, without the prior written permission of Langer EMV-Technik GmbH. The management of Langer EMV-Technik GmbH accepts no liability for damage resulting from the use of this printed information.