



User Manual

ICI-DP set

Double Pulse Magnetic Field Source Set



- Translation of the original German user manual into English -

Contents:	Page
1 Declaration of Conformity	4
2 General information	5
2.1 Storage of the user manual	5
2.2 Reading and understanding the user manual	5
2.3 Local safety and accident prevention regulations	5
2.4 Images	5
2.5 Limitation of liability	5
2.6 Errors and omissions.....	5
2.7 Copyright.....	5
3 Safety	6
3.1 Labels and signs	6
3.2 Intended use	6
3.3 Reasonably foreseeable misuse.....	7
3.4 Staff requirements	7
3.5 Safety instructions	7
4 Scope of delivery	9
5 ICI-DP Set	10
5.1 System description	10
5.2 BPS 204.....	10
5.2.1 Overview	10
5.2.2 Delay line	13
5.3 ICI-DP Probes	14
5.3.1 Overview	14
5.3.2 Measuring outputs „shunt out 1 / 2“	17
5.3.3 Trigger inputs „sync in 1 / 2“	17
6 Operating modes	18
6.1 Free-running operation (pulses not synchronised).....	18
6.2 Synchronised operation (pulse synchronised to external event).....	19
6.2.1 Synchronised single-pulse operation via BPS 204 <i>sync input</i>	19
6.2.2 Synchronised double-pulse operation via BPS 204 <i>sync input</i> using single trigger	20
6.2.3 Synchronised double pulse operation via BPS 204 <i>sync input</i> using double trigger.....	20
6.2.4 Synchronized (double) pulse operation via ICI-DP <i>sync in 1 / 2 input</i>	21
7 Control via BPS 204-Client	24
7.1 Overview	24
7.2 Detailed instructions for using the BPS 204-Client.....	24
7.3 Setting the different operating modes.....	26

8	Control via DLL	27
9	Measurement setup	28
10	Quick start	30
11	Technical data	31
11.1	ICI-DP HH 500-15 Probe	31
11.2	BPS 204 Burst Power Station	33
11.3	BPS 204-Client	33
11.4	Dimensions of the ICI-DP probe	34
11.5	Dimensions of the ICI-DP probe with varied holder	35
12	Information on Recycling and Disposal	36
13	Customer service	37
14	Warranty	38

1 Declaration of Conformity

Manufacturer:

Langer EMV-Technik GmbH

Nöthnitzer Hang 31
01728 Bannewitz
Germany



Langer EMV-Technik GmbH herewith declares that the

ICI-DP “xxx” set, Double Pulse Magnetic Field Source set including the products:

- **BPS 204**, Burst Power Station and
- **ICI-DP HH1000-15**, Double Pulse Magnetic Field Source and/or
- **ICI-DP HH500-15**, Double Pulse Magnetic Field Source and/or
- **ICI-DP HH250-15**, Double Pulse Magnetic Field Source and/or
- **ICI-DP HH150-15**, Double Pulse Magnetic Field Source

conforms with the following relevant regulations:

- EMC Directive 2014/30/EU
- Low-Voltage Directive 2014/35/EU
- Restriction of certain Hazardous Substances 2011/65/EU

The following applicable standards were used to implement the requirements specified by the a forementioned directives:

- DIN EN IEC 61000-6-1:2019-11 (EMC immunity)
- DIN EN IEC 61000-6-3:2022-06 (EMC emission)
- DIN EN 61010-1:2020-03 (Safety)
- DIN EN IEC 63000:2019-05 (Restriction of hazardous substances)

Name of the person authorized to compile the technical documentation

Katja Langer

Bannewitz, 2025-09-08

Signature:

A handwritten signature in black ink, appearing to be 'K. Langer', written over a horizontal line.

K. Langer, Managing Director

2 General information

2.1 Storage of the user manual

This user manual enables the safe and efficient use of the ICI-DP set. It must be kept close at hand and accessible to the use.

2.2 Reading and understanding the user manual

Read the user manual carefully, observe the safety information (Chapter 3) and follow the instructions given in this manual before putting the device into service.

2.3 Local safety and accident prevention regulations

The local accident prevention and general safety regulations also apply to ensure that the ICI-DP set is used for its intended purpose.

2.4 Images

Figures and images have been included in this user manual to assist the reader's understanding but may differ from the device's actual version.

2.5 Limitation of liability

In the following cases, Langer EMV-Technik GmbH can assume no liability for damage to property and personal injury if:

- The information given in this user manual has not been observed.
- ICI-DP set was operated by staff not qualified in the field of EMC.
- ICI-DP set was subjected to unauthorized modifications or technical changes.
- ICI-DP set was not used according to its intended purpose.
- Spare parts or accessories were used that had not been approved by Langer EMV-Technik GmbH.

The actual scope of delivery may deviate from the illustrations and texts in this user manual due to the customization of orders or due to technical changes and innovations.

2.6 Errors and omissions



The information in this manual has been carefully checked and is believed to be accurate; however, the Langer EMV-Technik GmbH assumes no responsibility for any clerical, typographical, or proofreading errors, or omissions.

2.7 Copyright

The content of this user manual is protected by copyright law and may only be used in connection with the ICI-DP set. This user manual may not be used for any other purpose without the prior written approval of Langer EMV-Technik GmbH.

3 Safety

3.1 Labels and signs

 <p>General warning sign</p>	 <p>Attention; electricity</p>	 <p>Prohibition sign; No access for persons with active implanted cardiac devices.</p>
<p>Table 1: Safety signs</p>		

Safety instructions are marked with symbols in this user manual. Observe these instructions and act carefully to avoid accidents and damage to persons and objects.

3.2 Intended use

The ICI-DP set is used for high-precision and high-resolution IC security analyses based on EM fault injection.

The ICI-DP set consists of one or more double pulse sources (e.g. magnetic field source) and the BPS 204 Burst Power Station.

The ICI-DP probes are equipped with high-resolution probe tips that enable the testing of extremely small areas. In addition, the ICI-DP probes are characterised by a very low trigger pulse delay and very low jitter, which makes it possible to disturb a very specific point in time during the programme sequence of an IC under test.

The ICI-DP probes are connected to the BPS 204 Burst Power Station, which provides the high voltage supply and control signals. The BPS 204 is connected to a computer via a USB interface and is controlled via the BPS 204-Client software or the DLL functions supplied.

Areas of application (a selection):

- EM fault injection and analysis (EMFI)
- EM pulse coupling

The user must follow all information and instructions in this user manual.

The ICI-DP set may only be used in an environment with a temperature of 10 to 30 degrees Celsius and a humidity of 20 to 85 per cent without condensation.

3.3 Reasonably foreseeable misuse

	Danger due to misuse!
	Incorrect use of the ICI-DP set can lead to dangerous situations!
Attention!	

The faulty applications of the sets include

- Use of the product outside the stated specifications.
- Modification or alteration of the product without the consent of Langer EMV Technik GmbH.
- Operation of the product with a technical defect.

3.4 Staff requirements

Only trained or experienced personnel in the field of IC security or EMC may operate the ICI-DP probe.

Persons whose performance is impaired by alcohol, drugs or medication must not operate the ICI-DP set.

3.5 Safety instructions

	Danger from electricity!
	Risk of injury due to electric shock!
Attention; electricity!	

High voltage can cause irreversible damage to the body, therefore the following safety instructions must be observed.

- All cable connections must be closed before operating the ICI-DP set.
- Do not touch the probe tip of the ICI-DP when it is in operation.
- If the insulation is damaged (e.g. cables), the power supply must be disconnected immediately.
- Damaged parts must be replaced with undamaged parts before commissioning. Contact Langer EMV-Technik GmbH to obtain a replacement.
- Protect contacting parts from moisture to avoid short circuits.
- Never leave a Langer EMV-Technik GmbH product unattended while it is in operation.

Always check all attachments, measuring devices, cables and probes before using the ICI-DP set. Never use damaged or defective devices.

Only employees of Langer EMV-Technik GmbH may open the ICI-DP probes or the BPS 204 and work on the electrical components and electrical cables.

If you notice any damage to lines, cables or electrical components, switch off the device immediately, pull out the mains plug, secure the ICI-DP set against being switched on again and contact Langer EMV-Technik GmbH!

	<p>Danger from electromagnetic fields!</p> <p>Risk of interference with a pacemaker!</p>
<p>Ban; no access for people with active implanted heart devices</p>	

Electromagnetic near fields are generated on the probe due to its function. For this reason, persons with a cardiac device, such as a pacemaker, must not work on or approach the ICI-DP set during operation.

4 Scope of delivery

No.	Designation	Type	Quantity
1.	Double Pulse Magnetic Field Source (s)	ICI-DP xxx	1-3
2.	Burst Power Station	BPS 204	1
3.	Communication cable, Fischer-Fischer	SK FI-FI 7p 1 m	1
4.	High-voltage cable, Fischer-Fischer	HV FI-FI mini 1 m	1
5.	SMA-SSMB measuring cable	SMA-SSMB 1 m	4
6.	USB cable	USB-A / USB-B	1
7.	Power supply unit	24 V / 1.25 A	1
8.	USB stick with BPS 204-Client		1
9.	System case	ICI-DP case	1
10.	Quick start		1
11.	User Manual		1

Note: The scope of delivery may vary depending on the order.



Figure 1: Scope of delivery of the ICI-DP HH500-15 set

5 ICI-DP Set

5.1 System description

The ICI-DP set is used to couple fast transient pulses into ICs. The probes are optimised for high spatial and temporal resolution. This allows individual areas of ICs to be tested in a targeted manner. In addition to single pulses, it is also possible to generate double pulses.

Depending on the scope of delivery, the set consists of one or more ICI-DP probes, a high-voltage generator (BPS 204), a power supply and the connection cables. The BPS 204 is connected to a PC via USB and controlled using the supplied BPS 204-Client software or the included DLL/ so file.



Figure 2: BPS 204 with probe ICI-DP HH500-15

5.2 BPS 204

5.2.1 Overview

The BPS 204 is the supply and control unit for the ICI-DP probes. It supplies an adjustable high voltage from which the probe generates the disturbance pulses. It also transmits the parameters set by the user to the probe.

The BPS 204 is connected to the PC via a USB cable. The parameters of the BPS 204 can be set by the user using the supplied software (graphical user interface) or via the programming interface (DLL).

The disturbance pulses can be synchronised to external events via the "sync" input on the rear of the BPS 204, e.g. to sequences of an IC to be examined. For this purpose, the BPS 204 has a delay unit that allows the timing of the pulse generation to be adjusted via software (see section 6.2).

The setting of the parameters using the graphical user interface or programming interface is described in chapter 7 or 8 respectively.

The following figures show the connections of the BPS 204. Figure 3 shows the elements on the front, while Figure 4 shows those on the rear. The respective functions are described in Table 2:

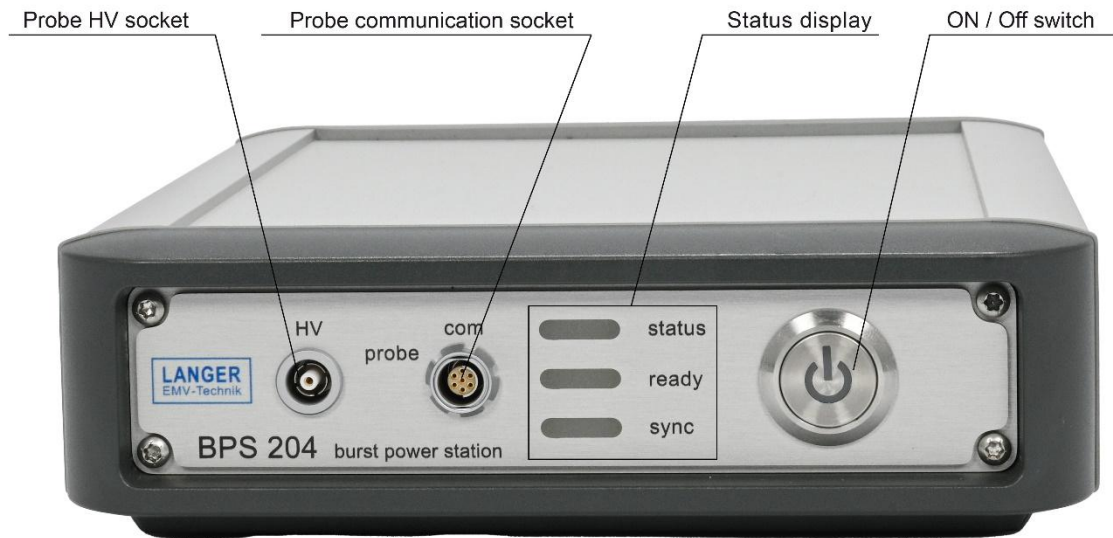

Figure 3: BPS 204 front view

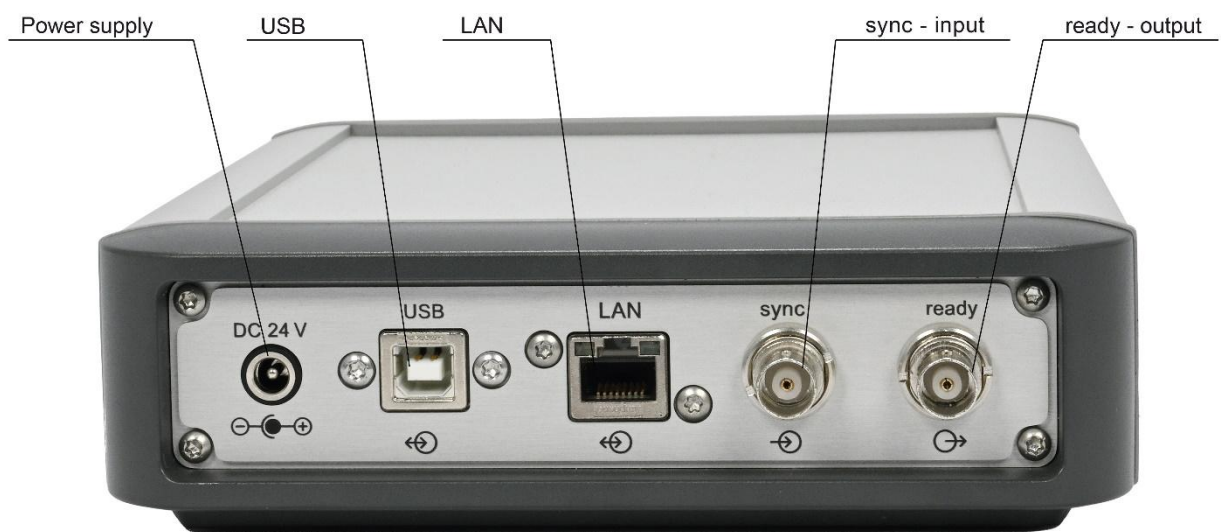

Figure 4: BPS 204 rear view

Table 3: Elements of the BPS 204

Element	Description of the
<i>Front view</i>	
probe high-voltage socket	Output of the internal high-voltage generator: The probe must be connected to the BPS using the high-voltage cable.
Probe communication socket	Communication connection for the probe: The probe must be connected to the BPS using the communication cable.
Status display	LED display panel: signals the functional status of the BPS 204 (see Table 4).
On/off switch	Pressing the switch turns on the BPS 204 and sets it to its default state. All settings (parameters) can be made using the BPS 204-Client or DLL when the BPS 204 is switched on.
<i>Rear view</i>	
Power supply (24V / 1A)	Power supply for the BPS 204 and the connected probe.
USB	USB interface for connecting the BPS 204 to a PC.
LAN	<i>Not implemented in current revision 1.</i>
"sync" input (BNC)	Trigger input (5V tolerant): In synchronised operating mode, pulses are triggered in the probe depending on the trigger signal (see chapter 6 Operating modes)
"ready" output (BNC)	"Ready" output: Output of 5V (logic high level) when the set high voltage is stable and a pulse can be triggered by an external trigger signal. This parameter can also be queried via the DLL.

Table 4: Status display of the BPS 204

LED	Colour	Description of the
status	white	BPS is switched on and initialised without errors
	red	Error state of the BPS
ready	green	BPS activated and high voltage stable at set value
sync	yellow	BPS activated with external trigger and high voltage stable

Figure 5 shows the block diagram of the BPS 204. The blocks shown in green can be controlled via the BPS 204-Client or the DLL.

The adjustable parameters of the BPS 204 are:

- High voltage, corresponds to pulse intensity (pulse level)
- Selecting the pulse polarity (Pulse Polarity)
- Pulse frequency in non-synchronised mode (Pulse Frequency)
- Selection of single or double pulse sequence (Pulse Mode)
- Selection of whether the "sync" input should be used on the BPS or on the connected probe (trigger mode)
- Adjustable delay of the interference pulses (Main Delay, Delta Delay)

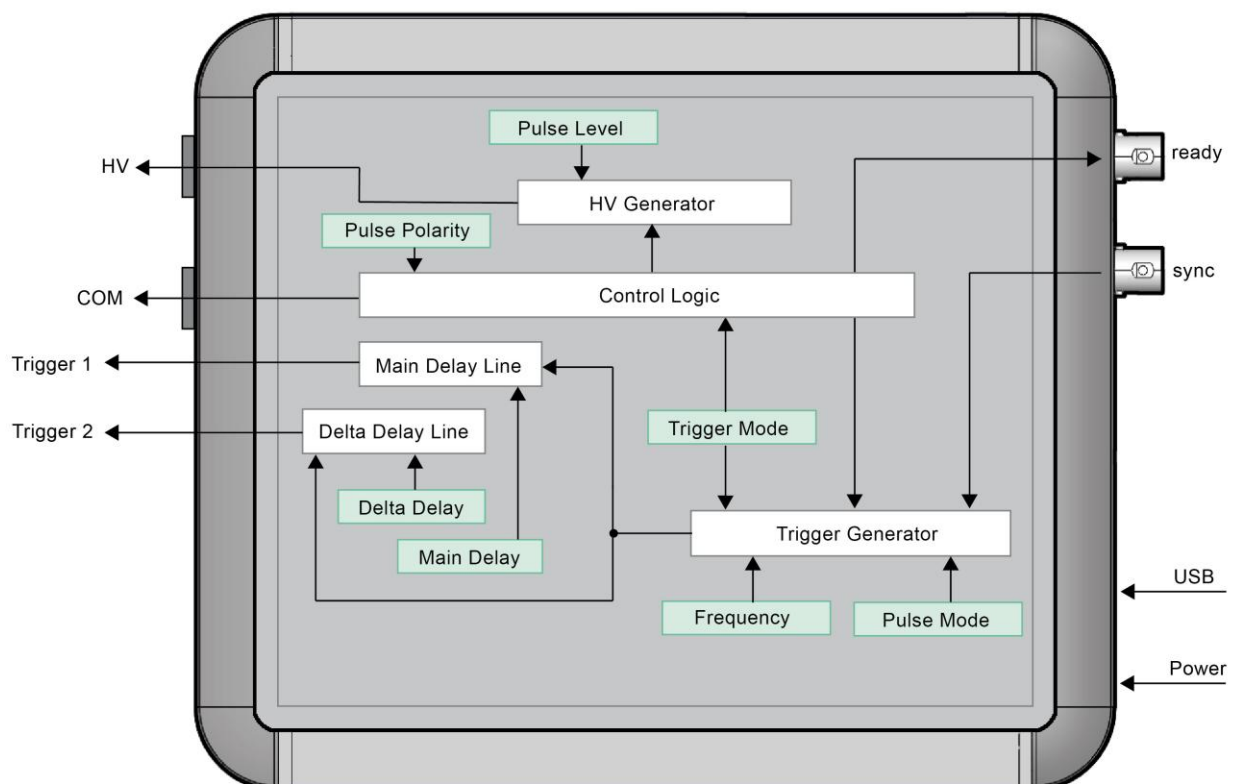

Figure 5: Block diagram of the BPS 204

5.2.2 Delay line

The BPS 204 includes a delay line with low jitter (< 300 ps). The delay of the external trigger signal (via the "sync" input) can be set in steps of approx. 0.7 ns. Depending on the operating modes (see section 6.2), the triggering of the first pulse ("Main Delay") can be delayed and/or the delay between the two pulses ("Delta Delay") can be set. The exact delay times are product-specific and are supplied in a product-specific data sheet.

5.3 ICI-DP Probes

5.3.1 Overview

The ICI-DP probes generate magnetic field pulses with different spatial resolutions. Tips with a diameter of 150 μm , 250 μm , 500 μm and 1000 μm are available.



Figure 6: ICI-DP probe types

The probe must be connected to the BPS 204 using both the high-voltage cable and the communication cable.

The intensity of the generated pulses is set via the level of the high voltage in the BPS 204. The pulse polarity can be defined via the software interface and is changed within the probe. In double pulse mode, both pulses have the same polarity.

Single or double pulses can be triggered in synchronised mode via trigger signals into the "sync in 1" and "sync in 2" input sockets (SSMB sockets) at the backside of the ICI-DP probe (see section 6.2.4).

The internal probe current for both channels can be monitored by connecting the SSMB outputs "shunt out 1" and "shunt out 2" to an oscilloscope using the SMA-SSMB cables supplied (see section 9).

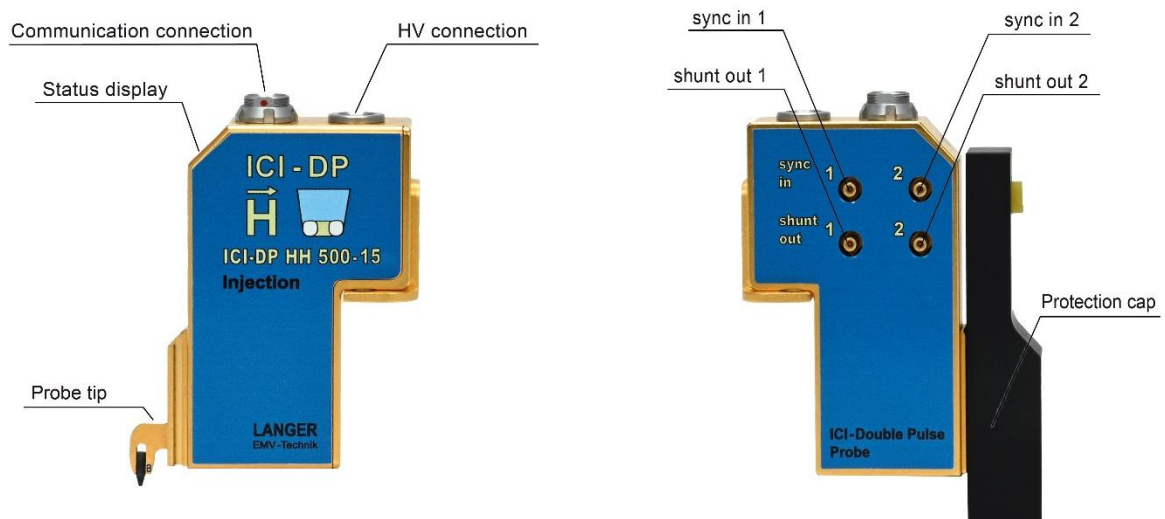

Figure 7: Front and rear view of the ICI-DP (example ICI-DP HH500-15)

Table 5: Elements of the ICI-DP

Element	Description
High-voltage connection socket at probe	High-voltage input of the probe: Must be connected to the BPS 204 via the high-voltage cable.
Communication connection socket at probe	Probe communication connection: Must be connected to the BPS 204 using a communication cable.
Status display	LED display panel, signals the functional status of the probe (for status information see Table 6)
probe tip	Depending on the probe, different versions couple the corresponding pulse to the test IC
„sync in 1 / 2“ (SSMB)	Pulse trigger input on the probe: the probe has two channels (1 and 2) that can trigger pulses in a very short sequence (see technical data).
„shunt out 1 / 2“ (SSMB)	Probe measurement output: the internally generated current can be measured for both pulse 1 and pulse 2 and the time of pulse generation via an integrated shunt.

Table 6: Operating states of the ICI-DP probe





Status display		Description
	Strobe	System start
	-	Probe is ready for operation
	2Hz	Probe generates pulses
	-	Probe error / hardware error
	2Hz	Bootloader mode (for firmware update)

Figure 8 shows the block diagram of the ICI-DP probe. Trigger 1 and 2, shown in green, can be controlled via the BPS 204-Client or the DLL or fed directly into the probe via an external signal. The pulse polarity can also be changed via the BPS 204.

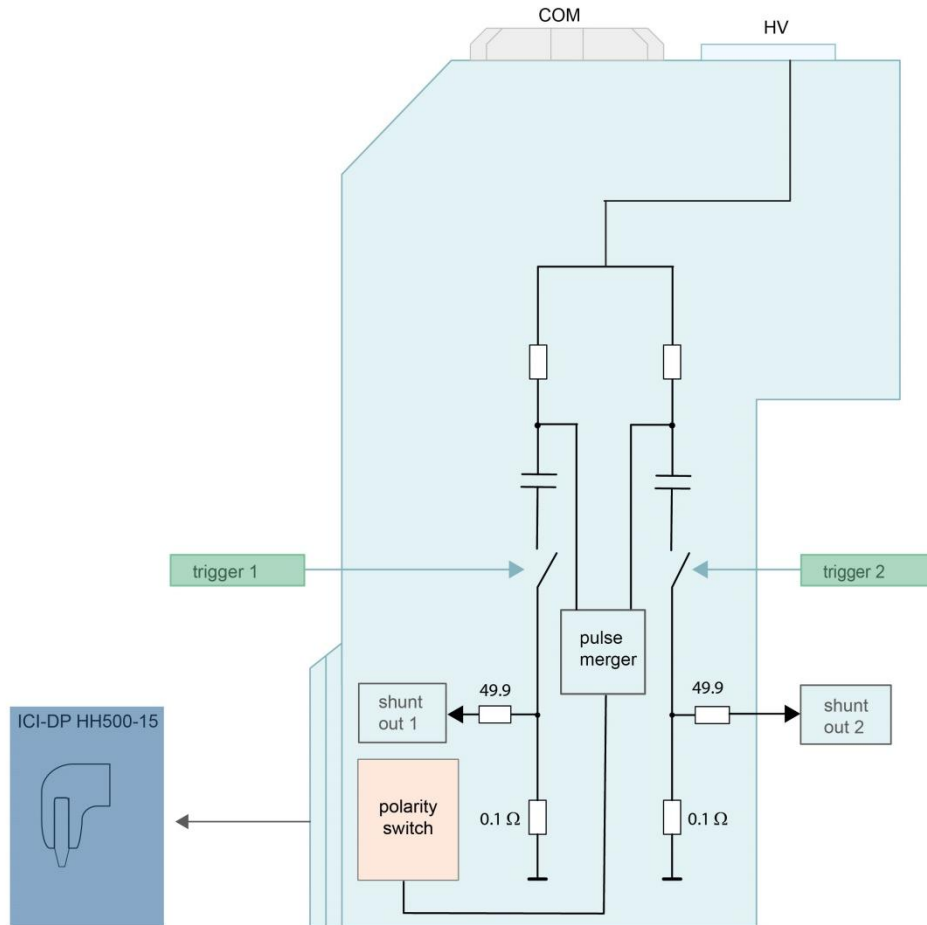

Figure 8: Block diagram of the ICI-DP

5.3.2 Measuring outputs „shunt out 1 / 2“

The two measurement outputs (*shunt out 1* & *shunt out 2*) of the ICI-DP probe can be used to measure the internally generated pulse current. To do this, the outputs are connected to the inputs of an oscilloscope. These inputs should be set to an input impedance of 50 Ω, otherwise additional oscillations will occur. With these settings, the pulse current through the measured voltage can be estimated using the following formula:

$$I_{pulse} = 8,02 * U_{shunt_out} \approx 8 * U_{shunt_out}$$

For example, if 2 V is measured at the *shunt out 1* output, a pulse current of approx. 16 A is generated. The following table provides an approximate overview of the pulse currents to be expected with the ICI-DP HH500-15 at various high voltages. The exact values are product-specific and are provided in a product-specific data sheet.

Table 7: High voltage with associated pulse current and voltage value at the measuring shunt.

High voltage [V]	Pulse current [A]	shunt-out [V]
150	4,5	0,6
300	8,5	1,1
450	11	1,4
600	13	1,6
750	15	1,9
1000	17	2,1

5.3.3 Trigger inputs „sync in 1 / 2“

The trigger inputs of the ICI-DP Probe "*sync in 1*" and "*sync in 2*" offer the possibility to react very quickly to an external event. The disturbance pulse is triggered by a rising edge at the corresponding inputs (SSMB sockets) with a very short and constant delay of only around 35 ns. The exact value is product-specific and is specified in the product-specific data sheet. This makes the inputs on the ICI-DP probe ideal if an external delay line is used. The trigger inputs have an input impedance of 50 Ω. The maximum input voltage of the trigger inputs is 3.3 V.

6 Operating modes

The ICI-DP set can generate single and double pulse sequences. In addition to the pulse intensity, the repetition frequency and the polarity, it is also possible to synchronise the generated pulses with external events and to set a delay between the external (trigger) event and the pulse(s). The desired pulse mode can be set using the BPS 204-Client software (see section 7) or via the supplied DLL (see section 8).

6.1 Free-running operation (pulses not synchronised)

In free-running mode, the pulse generation is performed exclusively by the BPS 204 with the settings in the BPS 204-Client (or DLL). The pulse sequence has the set frequency, pulse power and polarity and is not synchronised with external events.

In Figure 9, a schematic representation of the necessary setup for free-running operation is shown and in Figure 10 the resulting pulse sequence.

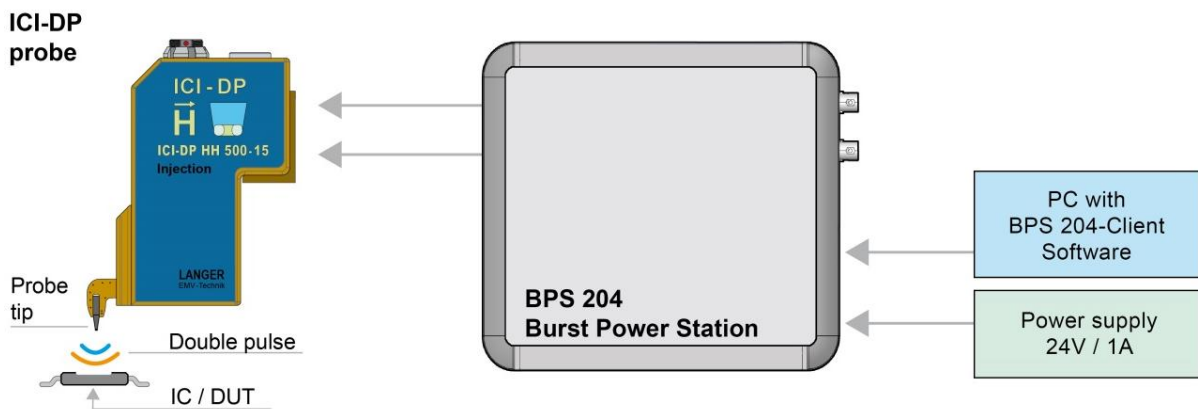

Figure 9: Set-up for free-running operation

In addition to single pulses with a specific frequency, it is possible to generate double pulses. These double pulses have a short time interval (only 25 ns between the two pulses), but require a recovery time afterwards (see Figure 11). The two pulses can be shifted in time to each other by software using the programmable delay unit integrated in the BPS 204.

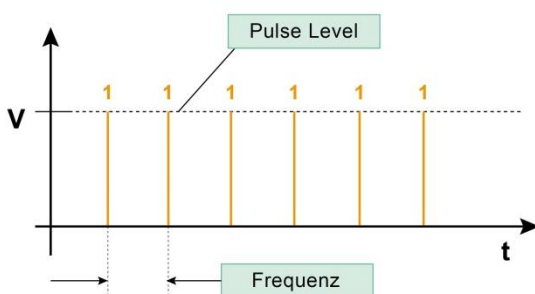

Figure 10: Continuous single pulse mode.

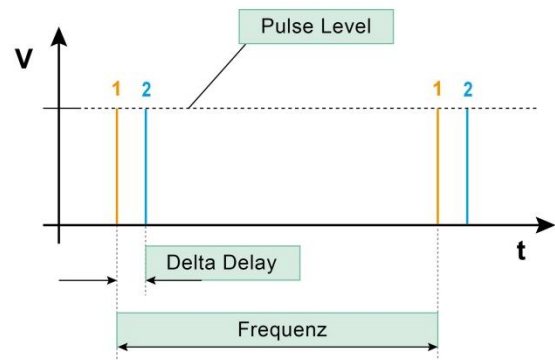

Figure 11: Continuous double pulse mode.

6.2 Synchronised operation (pulse synchronised to external event)

In synchronised mode, the pulse generation (single or double pulse) is started by an external trigger signal and thus synchronised to an external event, e.g. to a specific point in the program sequence of an IC to be tested.

At the ICI-DP set, this external trigger signal can be fed into the BPS 204 or the ICI-DP probe, depending on the desired functionality. Table 8 provides an overview of which trigger inputs should be used for which requirements.

Table 8: Comparison of trigger input BPS 204 and ICI-DP

	Trigger BPS 204	Trigger ICI-DP
adjustable delay	X	
double pulse from single trigger signal	X	
minimal trigger-to-pulse delay		X
separate triggers for both pulses		X

6.2.1 Synchronised single-pulse operation via BPS 204 *sync input*

In this synchronised mode, the individual pulse generation is triggered by an external trigger signal at the "sync" input of the BPS 204. The resulting pulse has the pulse height and polarity set by the software. In Figure 12 is a schematic representation of the necessary set-up for synchronised operation with a trigger in the BPS 204.

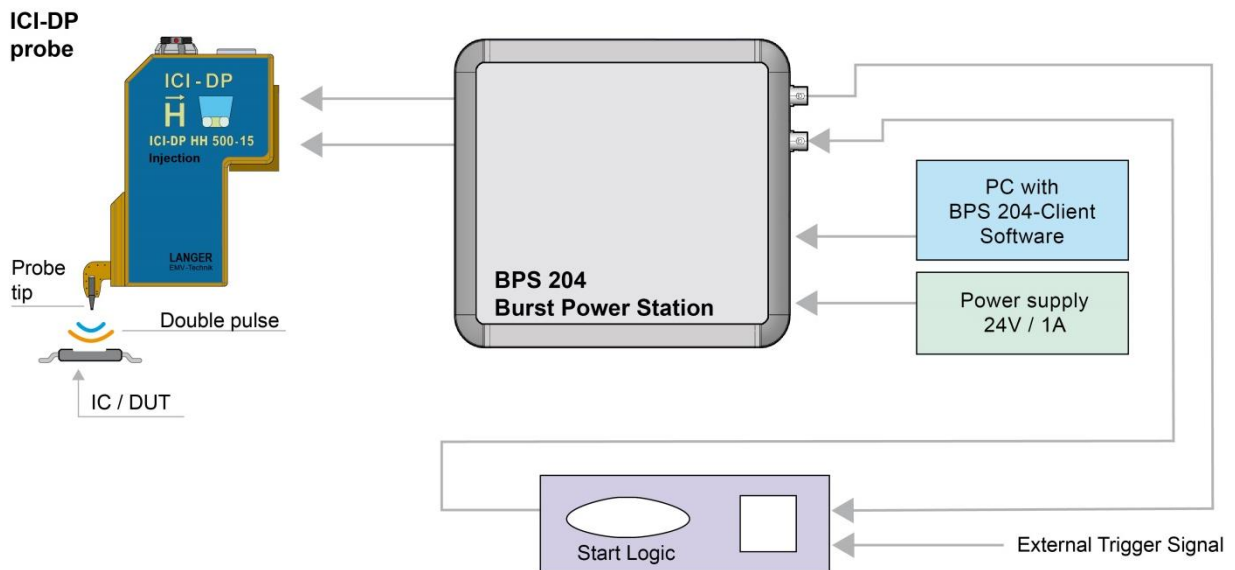

Figure 12: Measurement setup for synchronised operation via BPS 204.

In Figure 13 shows the resulting pulse sequence. After initialisation, the BPS 204 requires a certain amount of time t_{HV} to generate the desired high voltage. If this is stable, this is indicated via the "ready" output and can be read out using software. It is not recommended to trigger a pulse before this.

The pulse at the probe is generated after a defined time after the trigger signal is received by the BPS 204. Due to the design, there is a minimum delay time of approx. 100 ns between the trigger signal at the BPS 204 and the pulse of t_{T-P} . A further delay can be set via the integrated delay line using software ("Main Delay"). The exact delay values are listed in the product-specific data sheet.

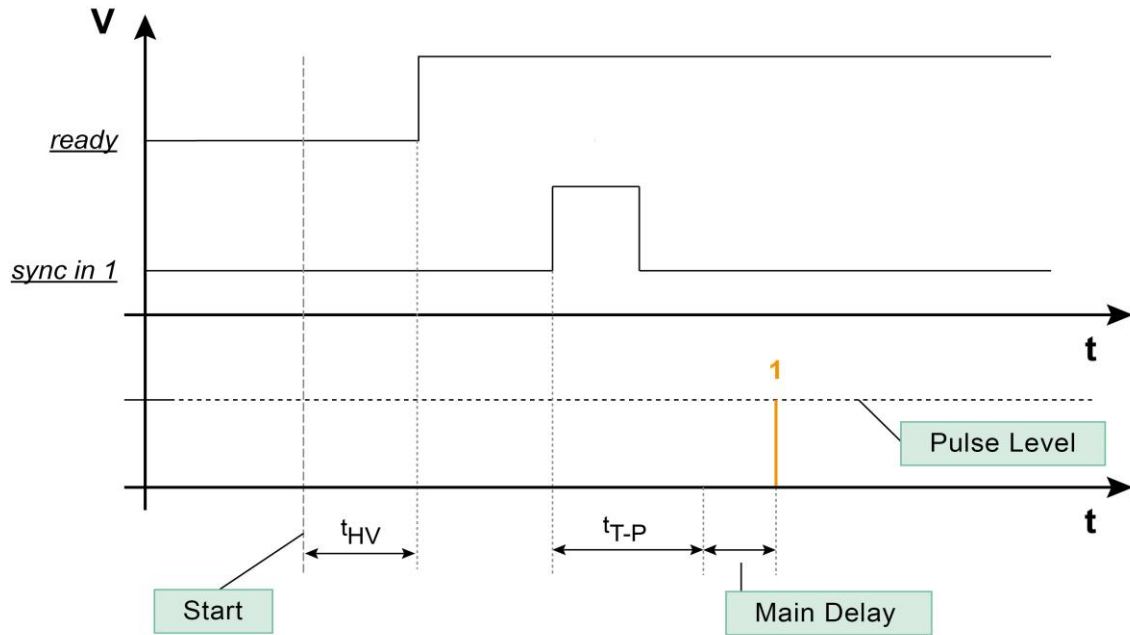

Figure 13: Synchronised (single) pulse operation

6.2.2 Synchronised double-pulse operation via BPS 204 sync input using single trigger

In this mode, a double pulse sequence can be generated using a single trigger signal. The setup still corresponds to that in Figure 12. In contrast to synchronised single pulse mode (see section 6.2.1), a (synchronised) double pulse is now generated from a single trigger. The distance between the two pulses and the general delay of the two pulses can be set by software. The shortest distance between the two pulses ("delta delay") cannot be less than the minimum value of approx. 25 ns. The resulting pulse sequence and the adjustable parameters are shown in Figure 14.

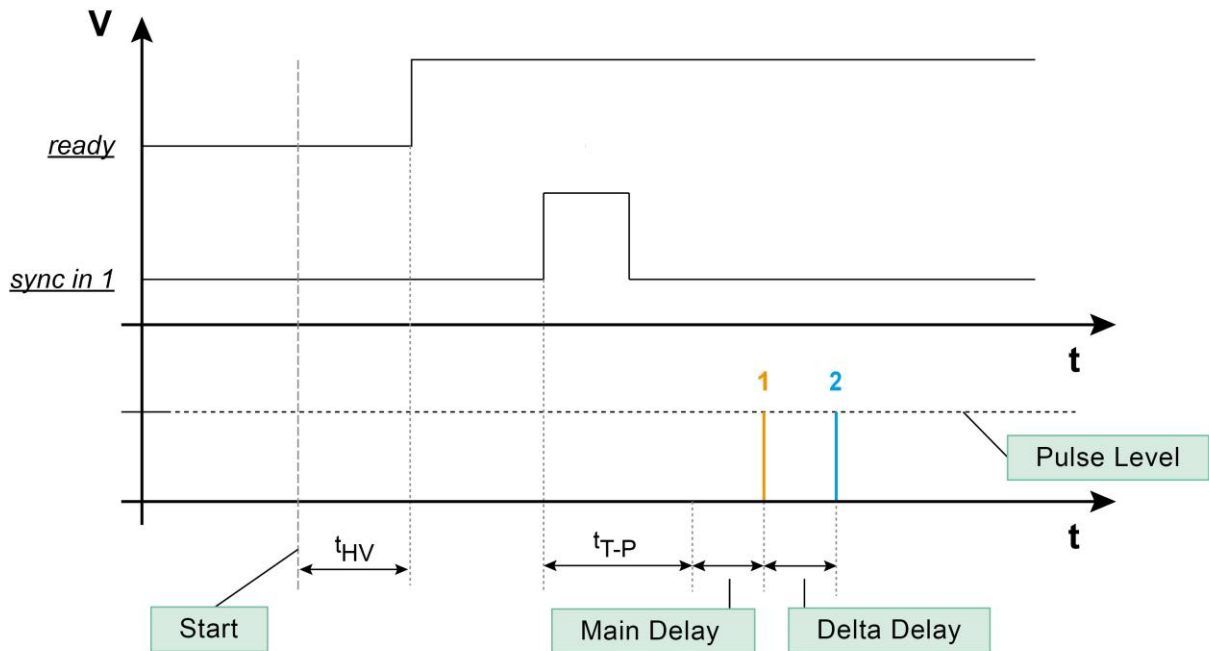

Figure 14: Synchronised double pulse operation from single trigger

6.2.3 Synchronised double pulse operation via BPS 204 sync input using double trigger

In contrast to the previous synchronised double pulse mode, in this mode the distance between the two individual pulses is not set using software but is specified externally. To do this, a corresponding trigger signal must be applied to the "sync" input, which has two trigger pulses at the desired time interval. The two pulses can be delayed together by the "Main Delay" value. The resulting pulse sequence is shown in Figure 15 is shown.

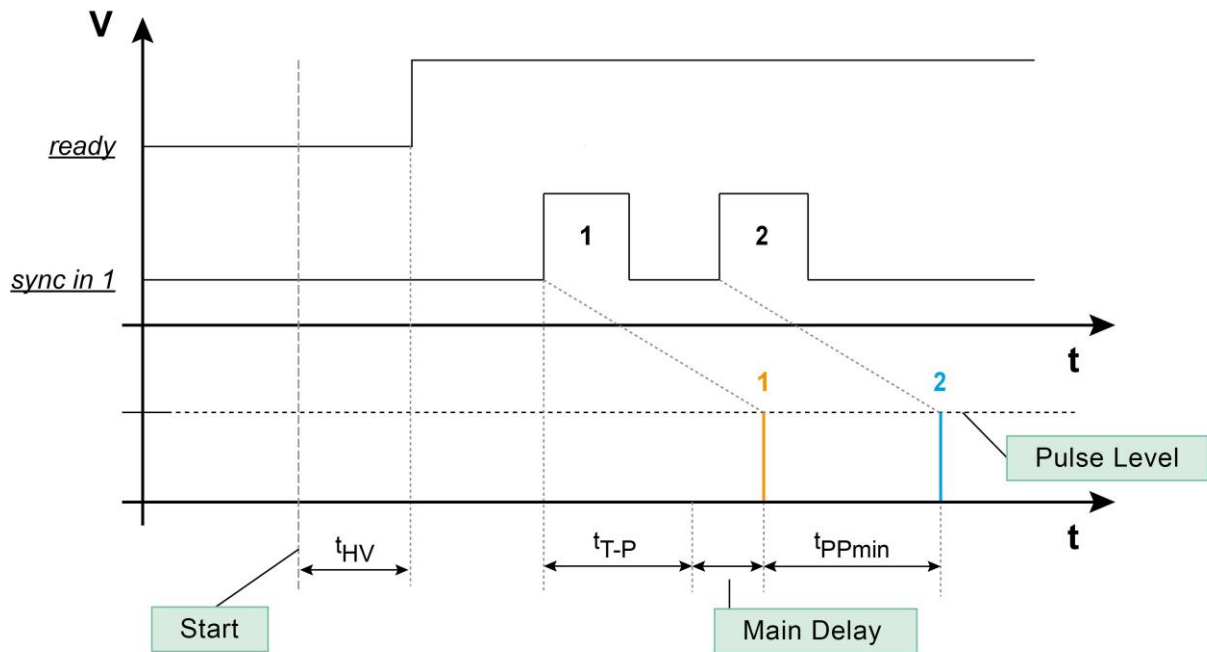

Figure 15: Synchronised double pulse operation, double trigger

6.2.4 Synchronized (double) pulse operation via ICI-DP sync in 1 / 2 input

In addition to the option of feeding the trigger signal into the BPS 204, the ICI-DP set also offers the option of triggering the pulses directly at the ICI-DP probe. This is particularly advantageous if a minimum trigger-to-pulse delay (t_{T-Pmin}) is required and no additional adjustable delay line is needed. The design-related minimum trigger-to-pulse delay is reduced to around 35 ns instead of 100 ns when the trigger is fed into the BPS 204. The necessary setup for synchronized operation when triggering into the ICI-DP probe is shown in Figure 16.

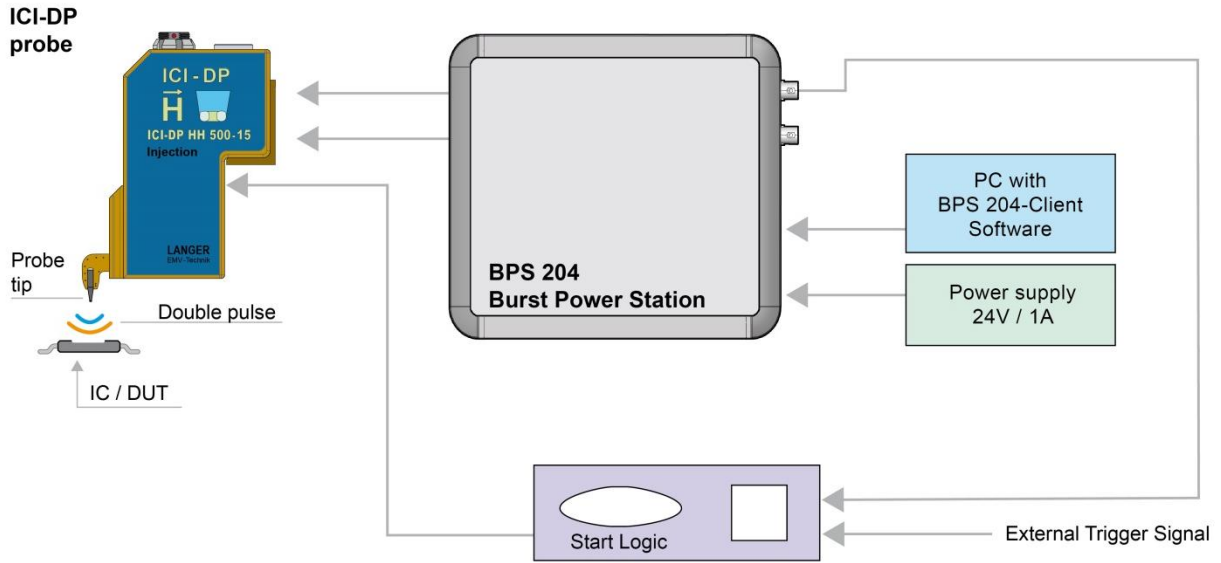

Figure 16: Measurement setup for synchronized operation via the **ICI-DP probe**.

Individual pulses can only be triggered by a trigger signal at *sync in 1*. A double pulse sequence can either be triggered by a trigger signal at *sync in 1* and *sync in 2* (cf. Figure 17) or by a double pulse trigger signal at *sync in 1* (cf. Figure 18).. For correct double pulse generation, the minimum distance between the two trigger pulses must not be less than $t_{PPmin} = 25 \text{ ns}$, which must be ensured by the user.

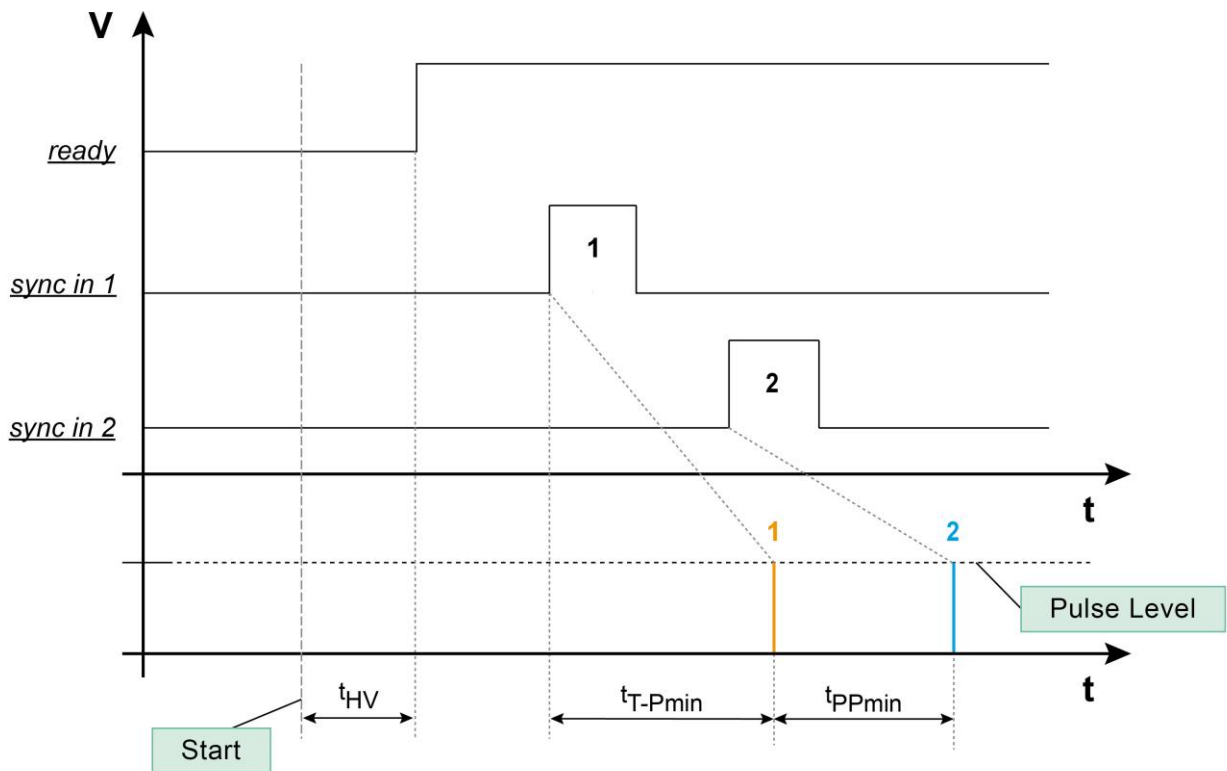

Figure 17: Synchronized double pulse operation, separated double trigger, ICI-DP

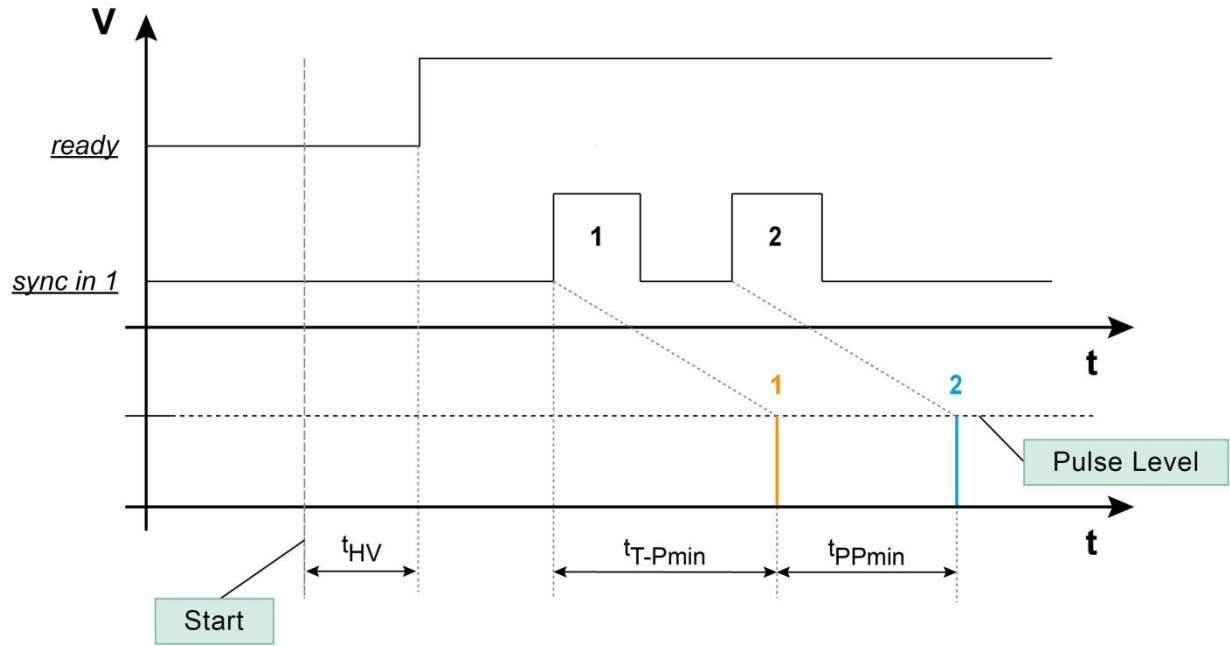

Figure 18: Synchronized double pulse operation, double trigger, ICI-DP

7 Control via BPS 204-Client

The parameters of the BPS 204 and the ICI-DP probes connected to it can be set using the BPS 204-Client. Depending on the selected mode, some parameters are not available and are greyed out accordingly.

7.1 Overview

If the BPS 204-Client is operated with the BPS 204 connected and switched on, the window below appears. The current data is retrieved from the BPS 204 and displayed. If the BPS 204-Client does not find a BPS 204, all fields are greyed out.

Figure 19 shows the main window of the BPS 204-Client. Starting with Pulse level, the adjustable parameters are displayed one below the other. The pulse level and the frequency can be changed using the slider as well as the number box. The polarity, pulse mode and trigger mode can be defined using radio buttons. The delay steps can be changed using the corresponding number box. In the lower area ("Control"), high-voltage generation is started by clicking on the "Start Pulsing" button. The text content of the button changes to "Stop Pulsing". Clicking this button again stops the high voltage and pulse generation.

The bottom section contains some status information such as BPS 204 status & probe status.

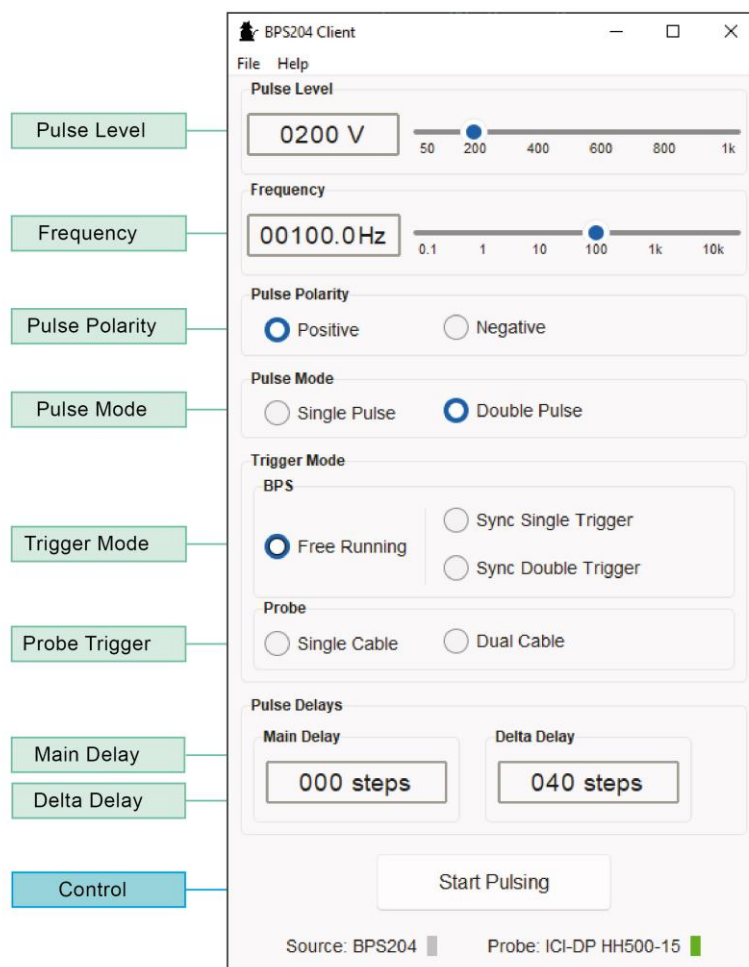

Figure 19: BPS 204-Client main window

7.2 Detailed instructions for using the BPS 204-Client

The BPS 204-Cclient offers various options for setting the high voltage (pulse level).

1. By clicking and moving the slider. The current value is displayed in the text field.
2. Click on the grey line of the slider. Clicking to the right of the slider button increases the level by 5 V, clicking to the left decreases it by 5 V.
3. Click on the displayed pulse level value to edit it. Enter the desired voltage value and confirm with ENTER.
4. Using the mouse scroll wheel. The voltage value is changed to the next full 10 V in the lower area and to the next 100 V in the upper area.

To 2. click next to the slider button



To 3. pulse level value in edit mode.



The same methods as for high voltage can be used to set the frequency in non-synchronized operation.

Additional information to the status information in the lower area can be displayed with a mouse over (hover effect) on the text "BPS 204" and "Probe: ..." or on the 2 small colored rectangles.

The mouse over at the texts displays information about the connected BPS 204 or probe, such as serial number, firmware version and device identification number.

Mouse over the colored rectangles to display the status information.

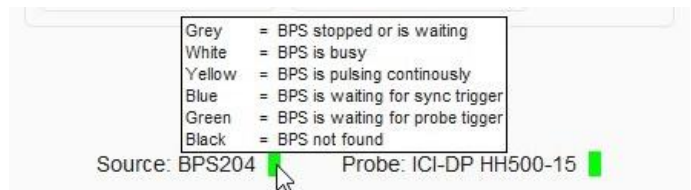

7.3 Setting the different operating modes

The following figures displays an example of the settings for some of the operating modes described in chapter 6.

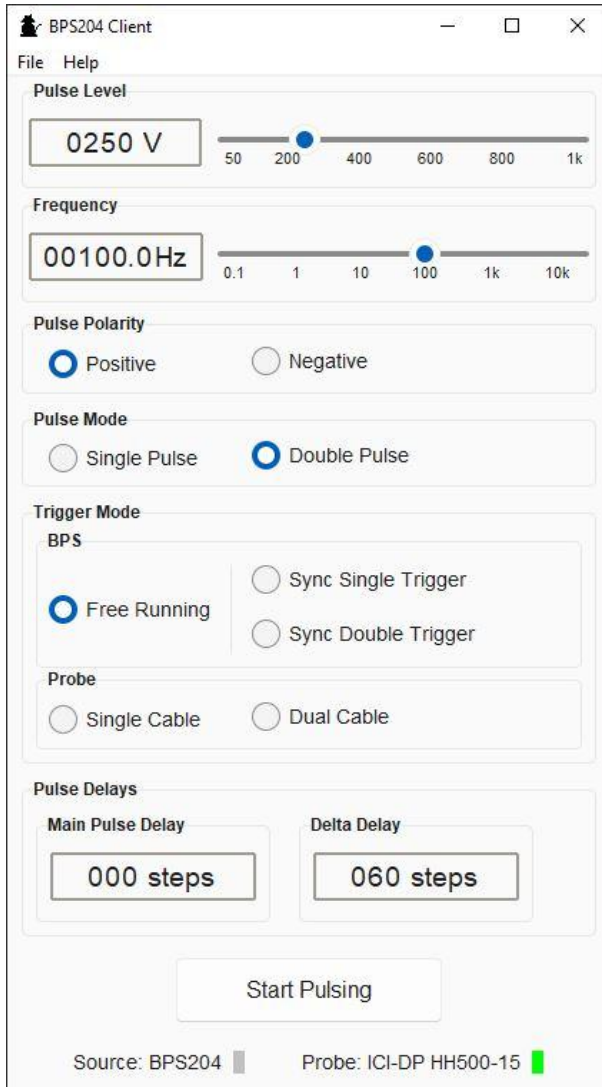

Figure 20: Free-running operation (pulses not synchronized)

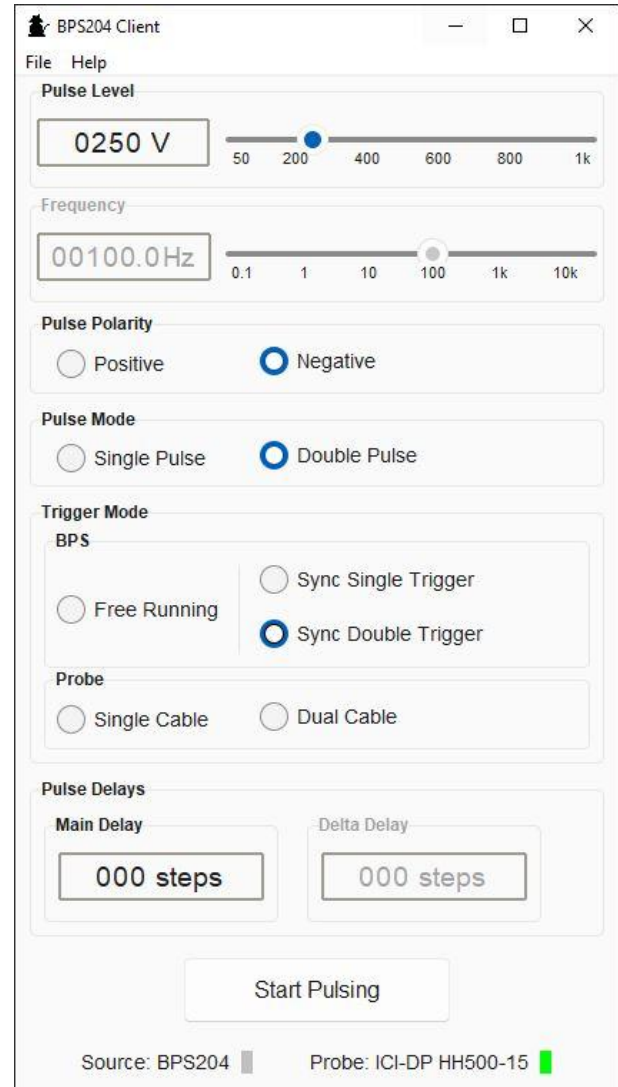

Figure 21: Synchronised double-pulse operation with trigger signal via BPS 204

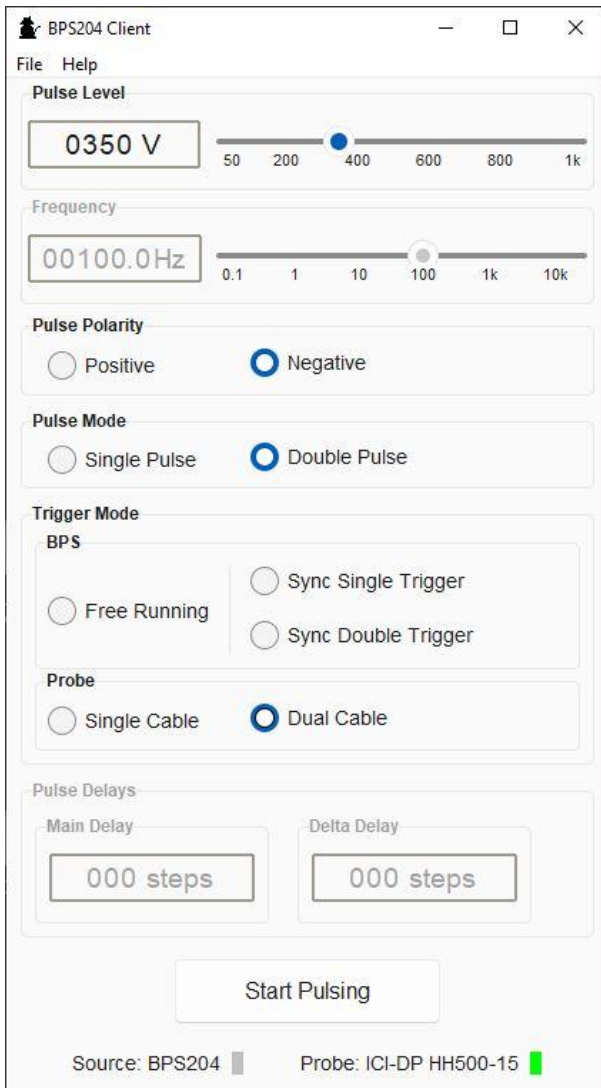

Figure 22: Synchronised double-pulse operation with trigger via ICI-DP

8 Control via DLL

All parameters that can be set with the BPS 204-Client can also be defined using the DLL supplied. This can be used for your own measurement automation. Please refer to the information in the *Programming Manual*, which can be found on the USB stick supplied and in the installation folder of the BPS 204-Client.

9 Measurement setup

Figure 23 shows a possible measurement setup of the ICI-DP set with an ICI-DP HH500-15 probe, which couples magnetic field pulses into a test IC (DUT). The components of the ICI-DP set used for this are listed in Table 9.

The DUT is put into operation as required and monitored via a test adapter or a control unit (e.g. CB0708). The ICI-DP probe is positioned over the IC using a suitable traversing system (e.g. ICS 105). The test IC and probe are monitored via an oscilloscope or a PC. Sensitive areas on the test IC can now be determined or weak points in its sequence code can be identified. The pulses (single or double pulse sequence) can be coupled into the test IC asynchronously or synchronously using the trigger inputs provided.

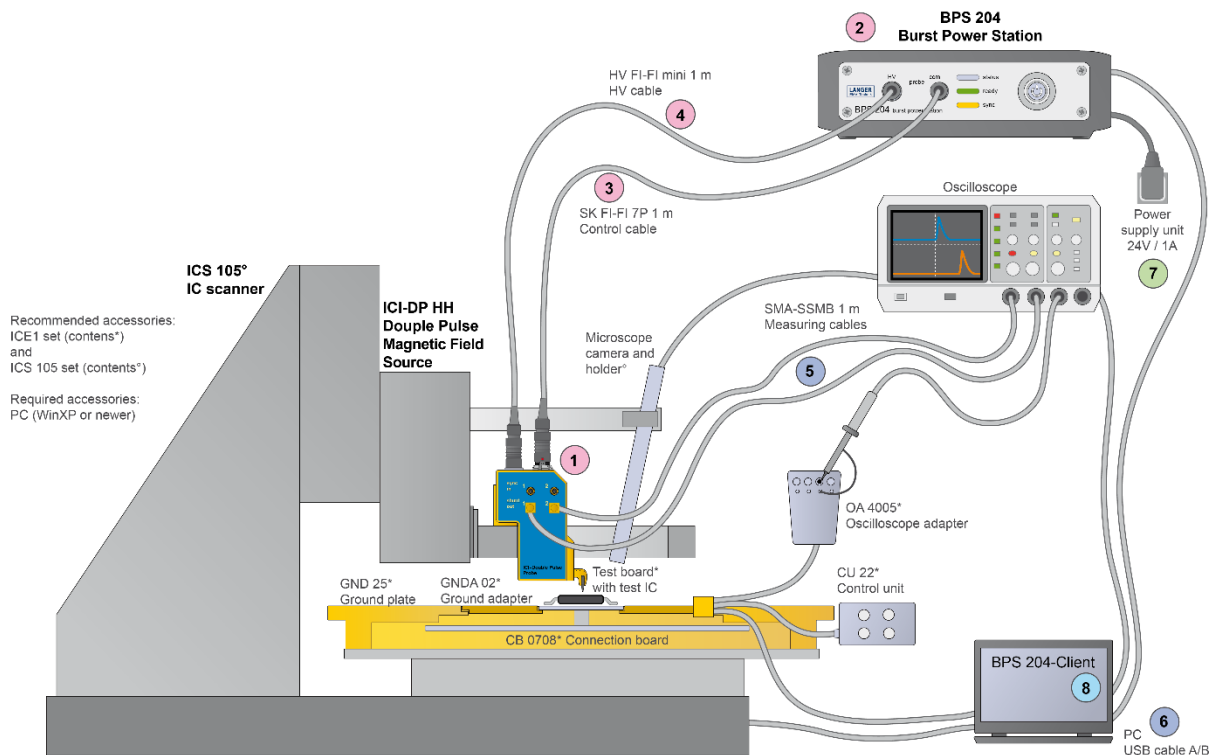

Figure 23: Practical measurement setup of the ICI-DP HH500-15 set.

Table 9: components of the ICI-DP set

No	Name	Description
1	ICI-DP HHxxx	Generates magnetic field pulses which couple into the test IC.
2	BPS 204	High-voltage generator and control unit for the probe
3	High voltage cable	Connects the BPS 204 to the ICI-DP probe
4	Communication cable	
5	Measuring cable	SMA-SSMB cable to connect the measurement output of the probe to an oscilloscope
	Trigger cable	SMA-SSMB cable to connect the probe to an external trigger source
6	USB cable	Connects the BPS 204 to a PC
7	Power supply unit	24V / 1A plug-in power supply unit, to power the set
8	BPS 204-Client ¹	PC software / DLL for controlling the set (Windows)

¹ Minimum requirements: Windows 10 or higher

10 Quick start

1. Check all components used for damage. Only proceed if all components are undamaged.
2. Install the BPS 204-Client on your PC.
3. Connect the BPS 204 and an ICI-DP probe with the enclosed high-voltage and communication cable.
4. Optional: Connect the two measurement outputs of the probe (*shunt out 1 / 2*) to an oscilloscope.
5. Connect the BPS 204 to the enclosed power supply unit.
6. Connect the BPS 204 to the PC using the USB cable supplied.
7. Switch on the BPS 204
8. Start the BPS 204-Client software.
9. Set the desired parameters on the BPS 204-Client.
10. Start pulse generation by clicking on "Start Pulsing".

11 Technical data

11.1 ICI-DP HH 500-15 Probe

Table 10: Technical parameters of the probe ICI-DP HH500-15

Power supply	via BPS 204
Dimension of the probe tip	Ø 500 µm
External trigger inputs (sync 1 & sync 2)	SSMB, max. 3.3 V
Measurement outputs (shunt out 1 & shunt out 2)	SSMB, max. 3 V
Max. coil current (typ.)	16 A
Max. magnetic flux density (typ.)	200 mT
Pulse parameters	
Rise time (10%-90%)	2 ns
Pulse width (50%-50%)	10 ns
Min. distance between the double pulses	25 ns (@ > 200 V/20% (pulse voltage)) 30 ns (@ < 200 V/20% (pulse voltage))
Repetition rate	0.1 Hz – 15 kHz (single pulse, < 500 V) 0.1 Hz – 7.5 kHz (double pulse, < 500 V)
Polarity (via software)	+ / -
Trigger-to-pulse delay	
Min. trigger-to-pulse delay (typ.)	35 ns
Max. Jitter (typ.)	± 1 ns
Impedance of the measuring output	50 Ω
Weight	190 g
Dimensions (D x W x H)	(26 x 54 x 71) mm

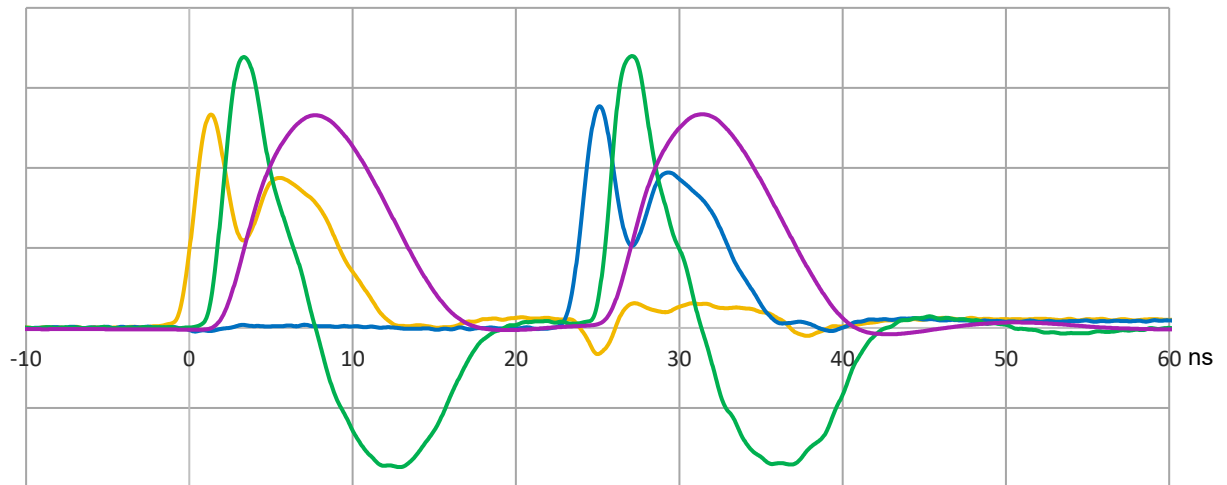

Figure 24: Typical time signals of the ICI-DP HH500-15 in double pulse mode.

Orange: Voltage at measuring output 1 (shunt out 1)

Blue: Voltage at measuring output 2 (shunt out 2)

Green: induced voltage in measuring coil

Purple: resulting flux density in the measuring coil.

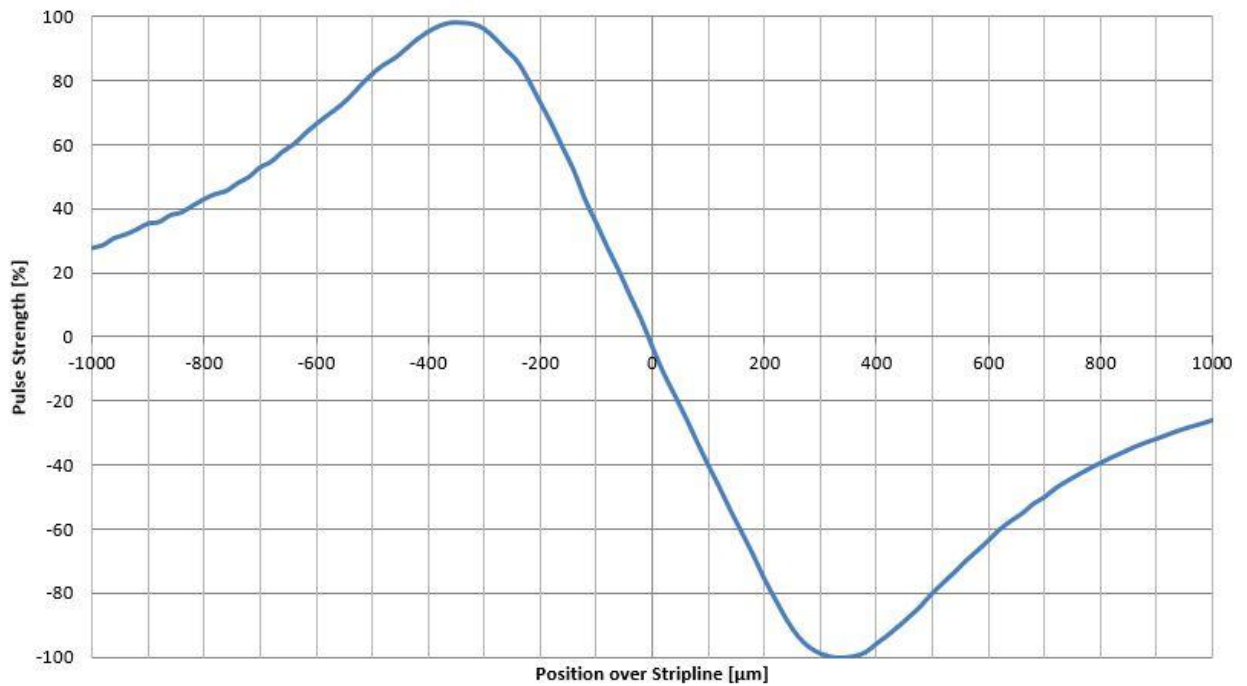

Figure 25: Relative pulse amplitude of the ICI-DP HH500-15 probe in a transverse scan over a 100 μm stripline.

11.2 BPS 204 Burst Power Station

Table 11: Technical parameters of the BPS 204 Burst Power Station

Output voltage	50 V - 1000 V
BPS ready output	BNC, max. 5 V
External trigger input	BNC, max. 5 V
Trigger-to-pulse delay	
Min. trigger-to-pulse delay (typ.)	100 ns
Max. Trigger-to-pulse delay (typ.)	420 ns
Step width of the delay (typ.)	0.7 ns
Max. Jitter (typ.)	< 300 ps
Interface	USB Type B Ethernet RJ45 (not active in current revision 1)
Power supply	24 V / 1.25 A DC
Dimensions (D x W x H)	(175 x 122 x 61) mm
Weight	300 g

11.3 BPS 204-Client

Table 12: System requirements for the BPS 204-Client software

Operating system	Windows 10 or Windows 11
Screen resolution	1024 x 768 or higher
Hard disc space	30 MB

11.4 Dimensions of the ICI-DP probe

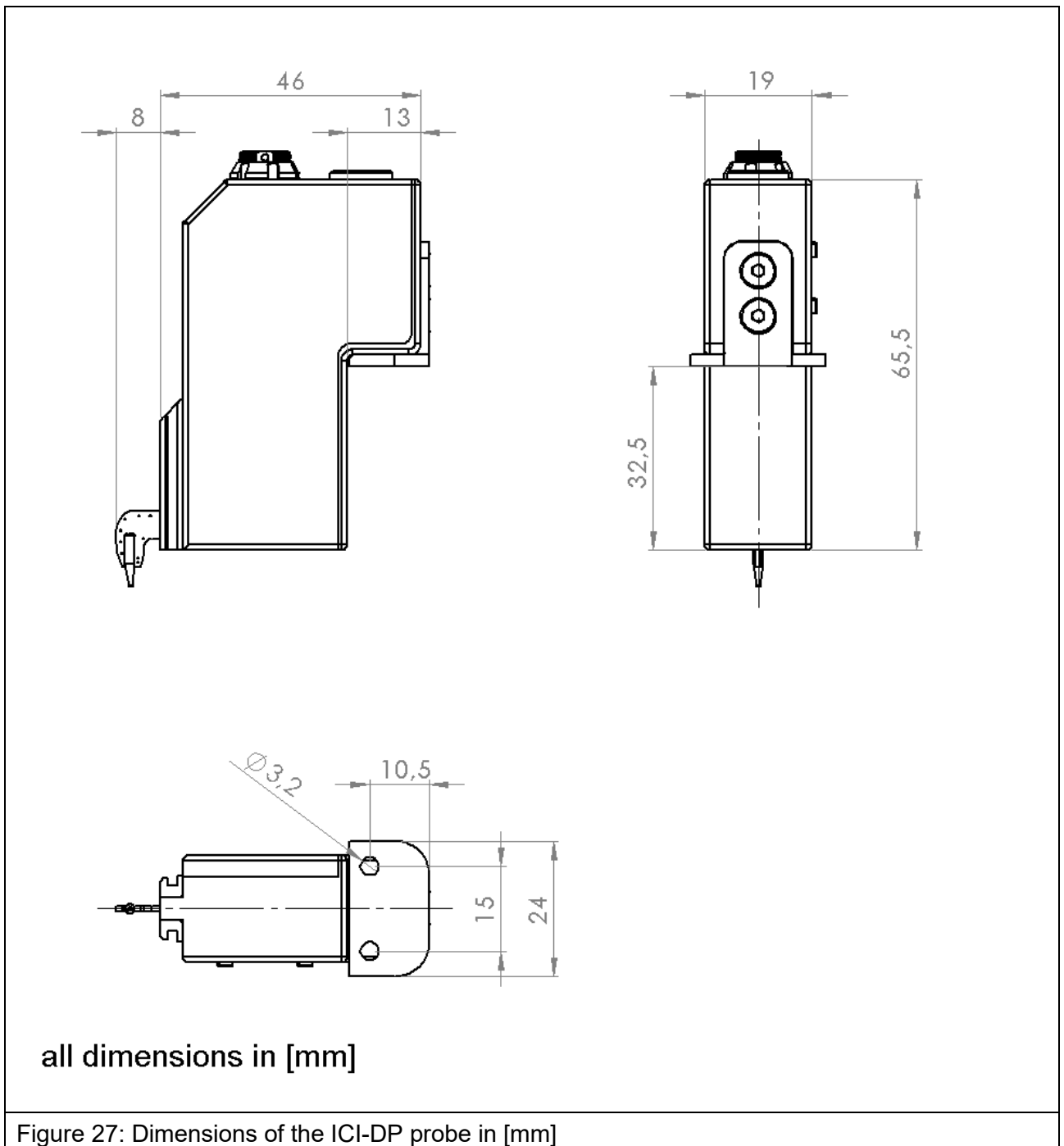
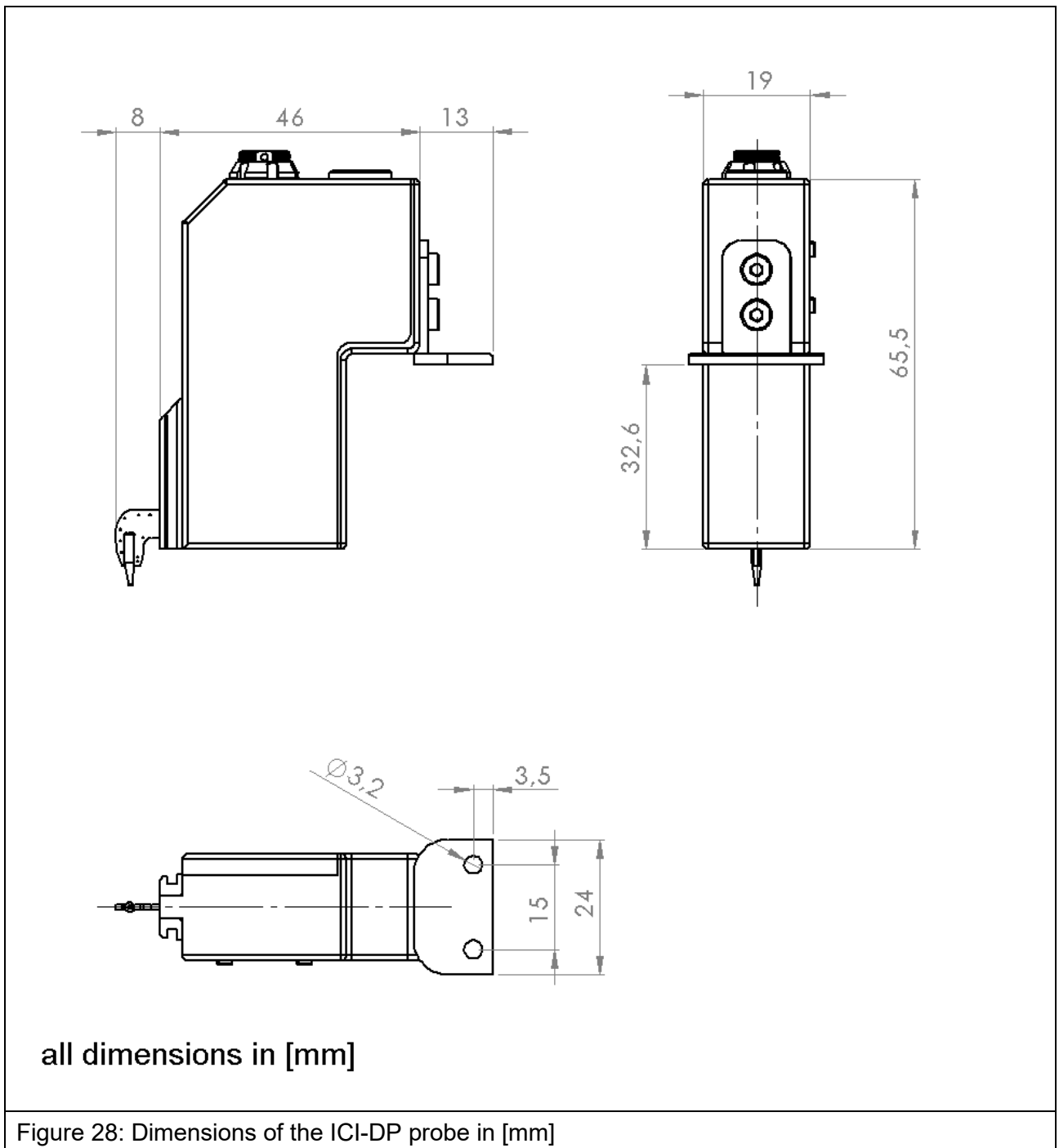

Figure 27: Dimensions of the ICI-DP probe in [mm]

11.5 Dimensions of the ICI-DP probe with varied holder



12 Information on Recycling and Disposal



DE 80567526

In accordance with the WEEE Directive 2012/19/EU (Waste of Electrical and Electronic Equipment), the following must be observed:

At the end of its service life, this product should be taken to a suitable disposal facility for recycling and disposal. Do not dispose of with household waste.

13 Customer service

Please contact us if you have any questions, comments or suggestions.

You can contact us:

Monday – Friday

8:00 Uhr bis 15 Uhr (CET)

Contact us at:

Address: Langer EMV-Technik GmbH
Nöthnitzer Hang 31
01728 Bannewitz
Germany

Internet: <https://www.langer-emv.com/>

E-mail: sales@langer-emv.de

Phone: +49 (0) 351-430093-0

Fax: +49 (0) 351-430093-22

Calibration

We recommend having the product calibrated every two years by the manufacturer Langer EMV-Technik GmbH or by a certified distributor.

14 Warranty

Langer EMV-Technik GmbH shall remedy all defects attributable to material or manufacturing faults within the statutory warranty period by repairing the product or supplying replacement parts.

This guarantee is only granted on condition that:

- the information and instructions in the operating instructions are observed.

The guarantee expires if:

- an unauthorized repair is carried out on the product
- the product is modified
- the product is not used as intended

This document may not be copied, reproduced or processed, duplicated or distributed using electronic systems, either in whole or in part, without the prior written permission of Langer EMV-Technik GmbH. The management of Langer EMV-Technik GmbH accepts no liability for damage resulting from the use of this printed information.