

## User Manual

# RF Current Transformer 100 kHz up to 1 GHz **HFW 21 set**



<b>Contents:</b>	<b>Page</b>
<b>1 Declaration of Conformity</b>	<b>4</b>
<b>2 General Information</b>	<b>5</b>
2.1 Storage of the User Manual	5
2.2 Reading and Understanding the User Manual	5
2.3 Local Safety and Accident Prevention Regulations	5
2.4 Images	5
2.5 Limitation of Liability	5
2.6 Errors and Omissions	5
2.7 Copyright	5
<b>3 Safety</b>	<b>6</b>
3.1 Labels and Signs	6
3.2 Intended Use	6
3.3 Reasonably foreseeable Misuse	6
3.4 Staff Requisition	6
<b>4 Scope of delivery</b>	<b>7</b>
<b>5 Measurement procedure</b>	<b>8</b>
<b>6 Description of the components</b>	<b>9</b>
6.1 HFW 21 RF current transformer	9
6.2 HFA 21 RF bypass	10
<b>7 Practical procedure</b>	<b>11</b>
7.1 Measuring with HFW 21 SET	11
7.2 Localization through global changes to the unit under test	11
7.3 Modification of the module	12
<b>8 Measurement set-up variants</b>	<b>13</b>
8.1 Measurement of the common-mode component	13
8.1.1 Unit under test with one cable terminal	13
8.1.2 Unit under test with several cable terminals	14
8.1.3 Unit under test with indispensable cables	14
8.1.4 Example: Measurements on a complex unit under test	15
8.1.5 External data lines	18
8.2 Measurement of the differential-mode component	19
<b>9 Technical parameters</b>	<b>20</b>
9.1 HFW 21 RF current transformer:	20
9.2 HFA 21 RF bypass	20

<b>10</b>	<b>Information on Recycling and Disposal</b>	<b>21</b>
<b>11</b>	<b>Customer service</b>	<b>22</b>
<b>12</b>	<b>Warranty</b>	<b>23</b>

# 1 Declaration of Conformity

Manufacturer:

Langer EMV-Technik GmbH  
Nöthnitzer Hang 31  
01728 Bannewitz  
Germany

Langer EMV-Technik GmbH herewith declares that the

**HFW 21 set**, RF Current Transformer 100 kHz up to 1 GHz

conforms with the following relevant regulations:

- Restriction of certain Hazardous Substances 2011/65/EU

The following applicable standards were used to implement the requirements specified by the aforementioned directives:

- DIN EN IEC 63000:2019-05 (Restriction of hazardous substances)

Note: This product does not fall within the scope of CE marking requirements, as it has no independent electrical function.

Name of the person authorized to compile the technical documentation:

Katja Langer

Bannewitz, 2025-12-16

Signature:



K. Langer, Managing Director

## **2 General Information**

### **2.1 Storage of the User Manual**

This user manual enables the safe and efficient use of the HFW 21 set. It must be kept close at hand and accessible to the use.

### **2.2 Reading and Understanding the User Manual**

Read the user manual carefully, observe the safety information (Chapter 3) and follow the instructions given in this manual before putting the device into service.

### **2.3 Local Safety and Accident Prevention Regulations**

The local accident prevention and general safety regulations also apply to ensure that the HFW 21 set is used for its intended purpose.

### **2.4 Images**

Figures and images have been included in this user manual to assist the reader's understanding but may differ from the device's actual version.

### **2.5 Limitation of Liability**

In the following cases, Langer EMV-Technik GmbH can assume no liability for damage to property and personal injury if:

- The information given in this user manual has not been observed.
- HFW 21 set was operated by staff not qualified in the field of EMC.
- HFW 21 set was subjected to unauthorized modifications or technical changes.
- HFW 21 set was not used according to its intended purpose.
- Spare parts or accessories were used that had not been approved by Langer EMV-Technik GmbH.

The actual scope of delivery may deviate from the illustrations and texts in this user manual due to the customization of orders or due to technical changes and innovations.

### **2.6 Errors and Omissions**




The information in this manual has been carefully checked and is believed to be accurate; however, the Langer EMV-Technik GmbH assumes no responsibility for any clerical, typographical, or proofreading errors, or omissions.

### **2.7 Copyright**

The content of this user manual is protected by copyright law and may only be used in connection with the HFW 21 set. This user manual may not be used for any other purpose without the prior written approval of Langer EMV-Technik GmbH.

### 3 Safety

#### 3.1 Labels and Signs


		
General warning sign	Warning; Electricity	Prohibition sign; No access for people with active implanted cardiac devices.
Table 1: Safety signs		

Safety instructions in this user manual are marked by symbols (**Table 1**). Observe the safety precautions and act cautiously to avoid accidents as well as personal and material damages.

#### 3.2 Intended Use

The HFW 21 set is a system of EMC tools for measuring the interference of assemblies and devices. Interference measurements taken during the development stage with HFW 21 set are proportional to the results from far-field measurements or from measurements with artificial networks. With the HFW 21 set tools disturbance sources can be localized, effects can be detected, and EMC measures individually determined. The effects of improvements implemented by HFW 21 set are proportional to the results from far-field measurements.

#### 3.3 Reasonably foreseeable Misuse

	<b>Danger resulting from misuse!</b> <b>Misuse of the HFW 21 set can lead to dangerous situations!</b>
Warning!	

Incorrect applications of the sets include:

- Use of the product outside of the given specifications.
- Modification or changes to the product without the consent of Langer EMV Technik GmbH.
- Operation of the product with a technical defect.

#### 3.4 Staff Requisition

Only qualified staff with training, knowledge, and experience in the field of EMC is allowed to operate the HFW 21 set.

Persons whose ability to perform is influenced or impaired by alcohol, drugs, or pharmaceuticals, are not allowed to operate the HFW 21 set.

## 4 Scope of delivery

Item	Designation	Type	Parameter	Quantity
01	RF current transformer	HFW 21		1
02	RF bypass	HFA 21		1
03	Probe tip			1
04	Cable, blue	LK 25 cm bl		1
05	Cable, red	LK 25 cm rt		1
06	Terminal block	AK 2 pole		2
07	Terminal block with header	AK ST 2 pole		2
08	Measurement cable	SMB-BNC 1 m		1
09	Measurement line, red	ML rt 7 cm		2
10	Measurement line, yellow	ML ge 12 cm		2
11	Measurement line, black	ML sw 25 cm		1
<hr/>				
12	User manual	HFW 21 m		1
13	Laminated quick guide	HFW 21 qg		1
14	HFW 21 SET system case	HFW 21 case		1

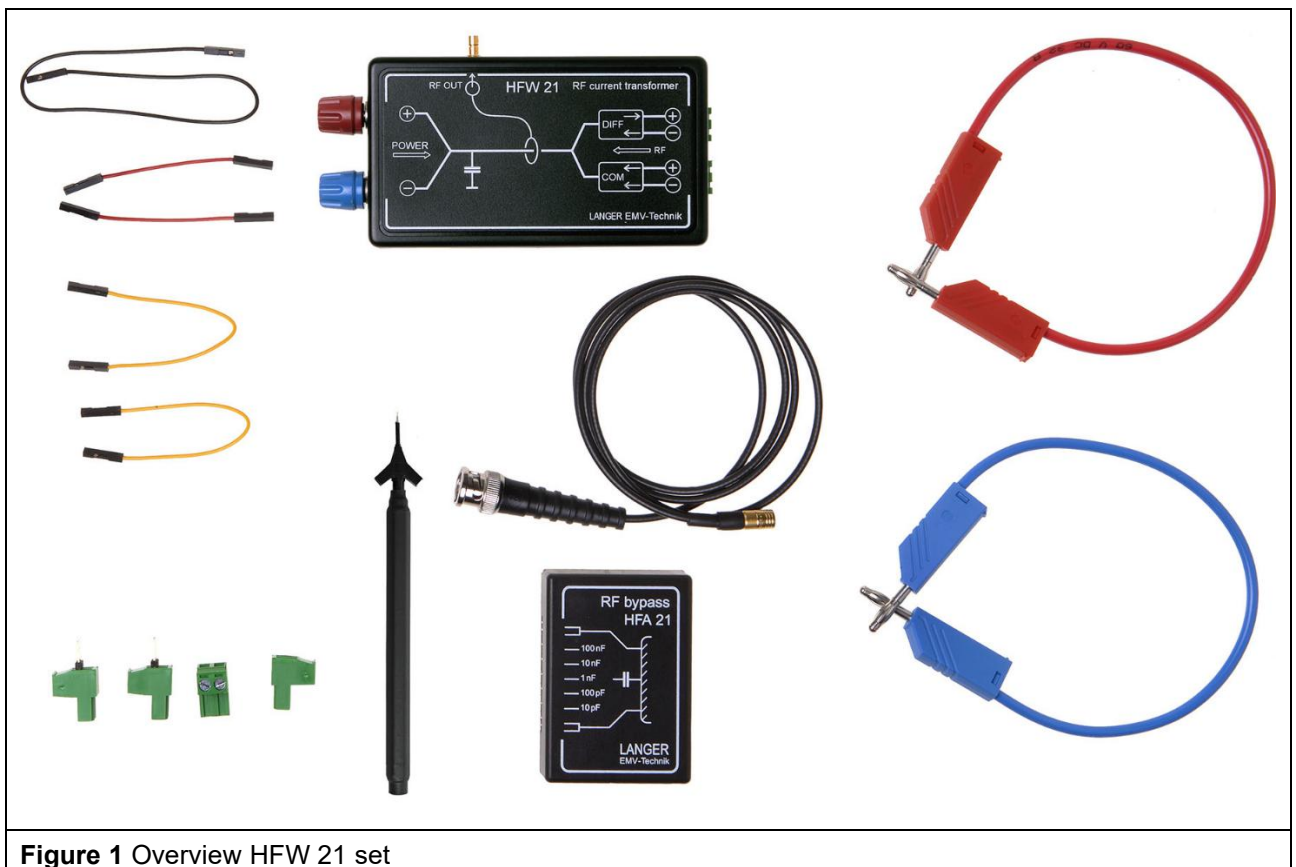


Figure 1 Overview HFW 21 set

## 5 Measurement procedure

The HFW 21 SET is suitable for carrying out comparative measurements of disturbances emitted by modules directly at the developer's workplace. Since the effect of any changes to the module becomes evident immediately, the time needed to optimize the unit under test can be dramatically reduced.

Measuring with the HFW 21 SET development system is based on the following considerations:

In most cases, it is not a component or conductor track of a unit under test that directly emits any disturbances, rather the entire metal system of the unit under test is excited through electric or magnetic coupling (i.e. in the near field). This metal system comprises the PCB itself and all connected cables and metal parts such as housings, shielding plates etc. in its immediate vicinity. The system in its entirety acts as an antenna and a source of emission. This excitation is roughly equivalent to the disturbances emitted by the unit under test. To determine this excitation, measure the exciting currents that flow, for instance, from a PCB to any cables connected.

The measurements are performed with a conductive ground plate to reduce any influences of the measurement set-up, cable positions and local fields. Inject all exciting currents through short capacitive coupling into the ground plate so that you have a small reproducible set-up (**Figure 2**).

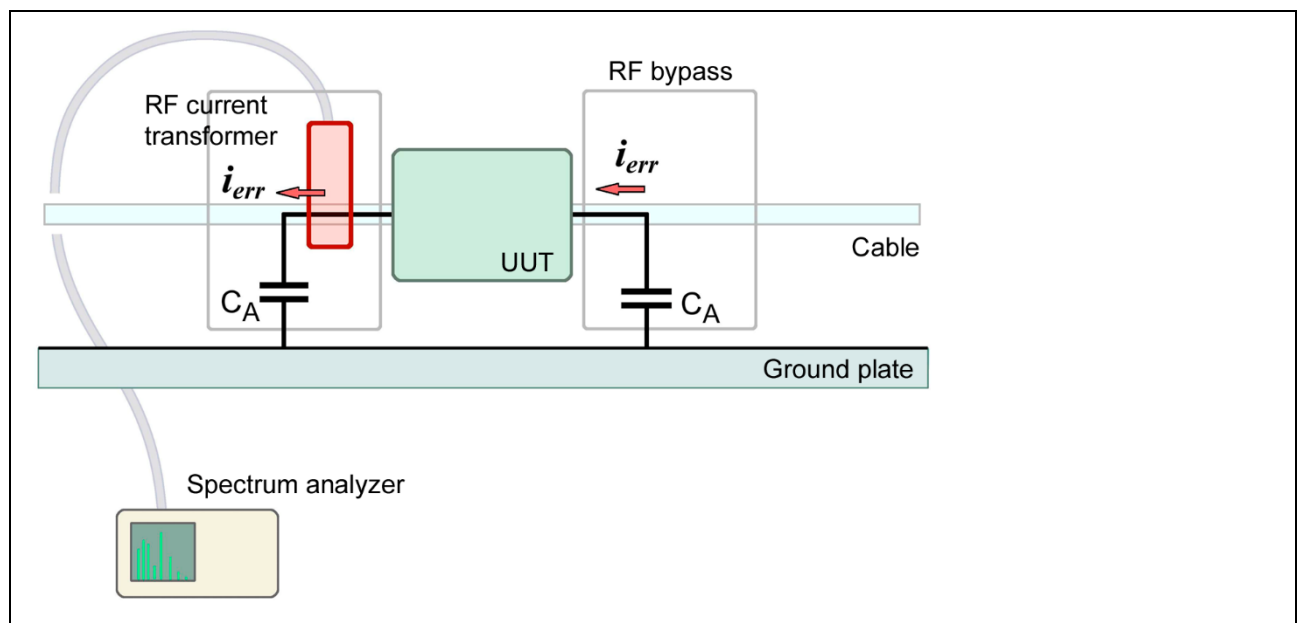
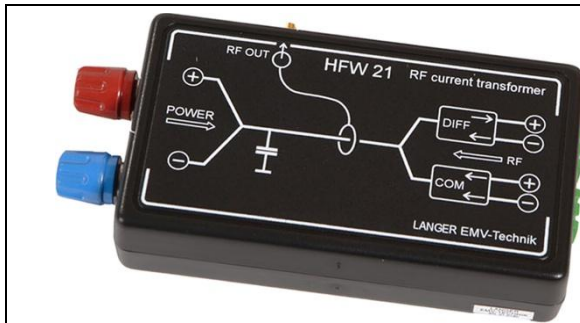


Figure 2

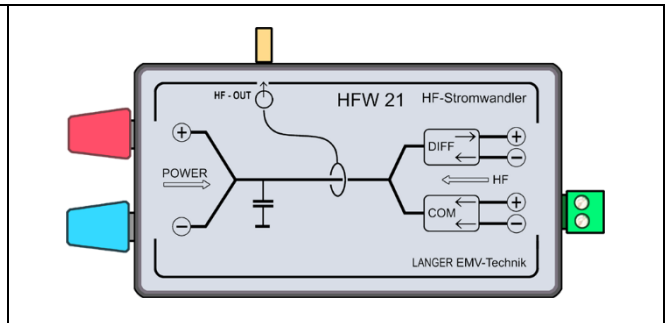
## 6 Description of the components

### 6.1 HFW 21 RF current transformer

The RF current transformer (Fehler! Verweisquelle konnte nicht gefunden werden. and ) measures high-frequency currents of up to 1 GHz on lines and diverts these currents to the base plate.



**Figure 3** HFW 21 RF Current Transformer



**Figure 4** HFW 21 RF Current Transformer (schematic)

The RF current transformer enables separate measurements of RF common-mode and differential-mode currents. In practice, you can do this by connecting the RF current transformer into the power supply circuit of the unit under test, for example. The supply voltage is connected to the "POWER" socket connector of the current transformer via laboratory cable with a 4 mm plug and the unit under test is connected to the "COM" or "DIFF" output via one of the supplied plugs. The RF currents emitted by the unit under test are thus passed through the transformer, measured (output above the 50 Ohm SMB socket) and diverted to the metal transformer ground plate through capacitive coupling.

If the unit under test is connected via the "COM" output, the RF current transformer measures the common-mode currents flowing on both lines whereas the differential-mode currents are measured via the "DIFF" output.

The RF output voltage is independent of the direct current flowing through the transformer if common-mode measurements are carried out. In case of differential-mode measurements, the RF output voltage decreases according to the diagrams shown in section 9.

#### Please note:

A current surge occurs on switching on depending on how the unit under test is connected. If the electrolytic capacitors, for example, are charged without limiting the current and the unit under test is connected via the HFW 21 differential-mode output, there is a risk of damage to the preamplifier or spectrum analyzer input!

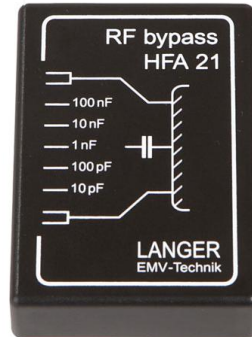
Always connect the HFW 21 to the PA 203 or spectrum analyzer after the unit under test has been switched on in such cases!

The same thing occurs during a short circuit in the unit under test if the electrolytic capacitors of the external power supply unit are abruptly discharged. There is no risk if the HFW 21 is operated via the common-mode output because these current pulses are compensated within the transformer.

Current peaks also occur if the supply of the unit under test is connected to earth and thus to the ground plate with an external power supply unit and the voltage in the unit under test is short-circuited to the GP 23 ground plate during the measurement:

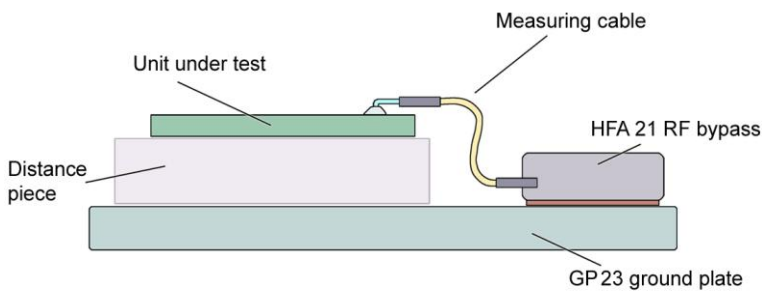
## 6.2 HFA 21 RF bypass

The RF bypass (**Figure 5**) supplements the RF current transformer by providing another capacitive or conductive connection from the unit under test to the ground plate if necessary.

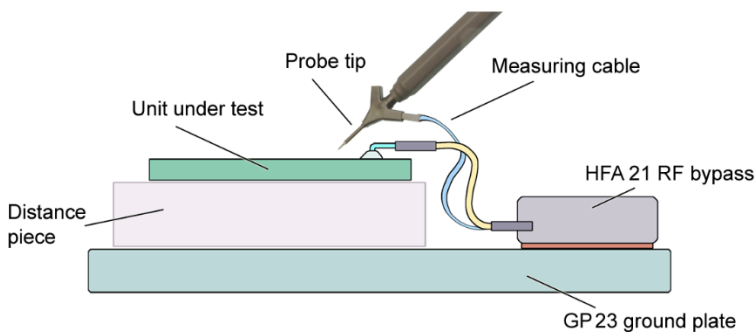


**Figure 5** HFA 21 RF Bypass

It is mainly used to simulate the data lines connected in normal operation and their capacitance relative to the surroundings. Instead of the data line, a discrete capacitance is connected to the signal output via a measuring line within the HFA 21 (**Figure 6**). Alternative it is possible to connect each single signal step by step to the capacitance by a Probe tip (**Figure 7**). Defined RF currents can thus be diverted to the ground plate. The HFA 21 contains capacitances from 10 pF to 100 nF.



**Figure 6**



**Figure 7**

## 7 Practical procedure

### 7.1 Measuring with HFW 21 SET

The measurements carried out with the HFW 21 SET are relative measurements. Thus it is important to define a measurement set-up and document the initial state first.

Measuring results from previous measurements under standard conditions provide crucial information on critical frequency ranges and the extent of necessary improvements. First analyze the measurement set-up required for these measurements:

- How have the PCBs been installed in the unit under test?
- Which connected cables are possible decoupling paths?
- How do these cables run inside and/or outside the unit under test? (e.g. cable harness in the car in the immediate vicinity of a large metal surface)
- Which metal parts such as housing, shielding, stud bolts, water pipes etc. are in the immediate vicinity (capacitive coupling)?

These considerations help determine modules and parts of modules as potential RF sources and find the paths by which the high-frequency currents are possibly emitted. This information allows you to design a measurement set-up so that the decisive emitted currents can be measured.

To confirm the measurement set-up, compare your measurement results with the results obtained in far-field measurements. There will be deviations of course. However, it is crucial in this comparison to find critical frequencies from far-field measurements with the chosen measurement set-up and thus to prove the existence of the suspected sources and associated decoupling paths.

### 7.2 Localization through global changes to the unit under test

The unit under test often allows you to locate the emission sources by changing the measurement set-up. These include

a) geometrical changes:

- Changing the distance between the unit under test and ground plate.
- Use sheet steel to simulate neighboring modules or housings.
- Plugging in and removing cables, changing the cable length and position.
- Eliminating individual RF sources by disconnecting individual modules, partial shielding or by using ferrite magnets.

b) changes to the operating procedure:

- Using another software or program or program section.
- Observing the spectrum when the program is running up.
- Switching off individual sections of the unit under test.
- Operating the unit under test under permanent reset conditions – only the clock line is maintained.

### **7.3 Modification of the module**

There are various starting points for modifying a module:

- a) Modifying the module's geometry with regard to
  - plug-and-socket connectors and cable connections
  - the layout
  - the surrounding metal system
  
- b) Changing the circuitry by
  - inserting damping resistors, filters
  - changing the operating procedure

The RF sources have to be modified so that the field strength is reduced (damping) or the lines of force are kept in the immediate vicinity of the source and do not exit the module.

Having detected the potential disturbing fields on the module, you will automatically have ideas and possibilities on how to reduce these fields. Potential modifications are:

- Confining the magnetic fields through metal surfaces
- Shielding electric fields through GND areas
- Inserting damping resistors in signal lines

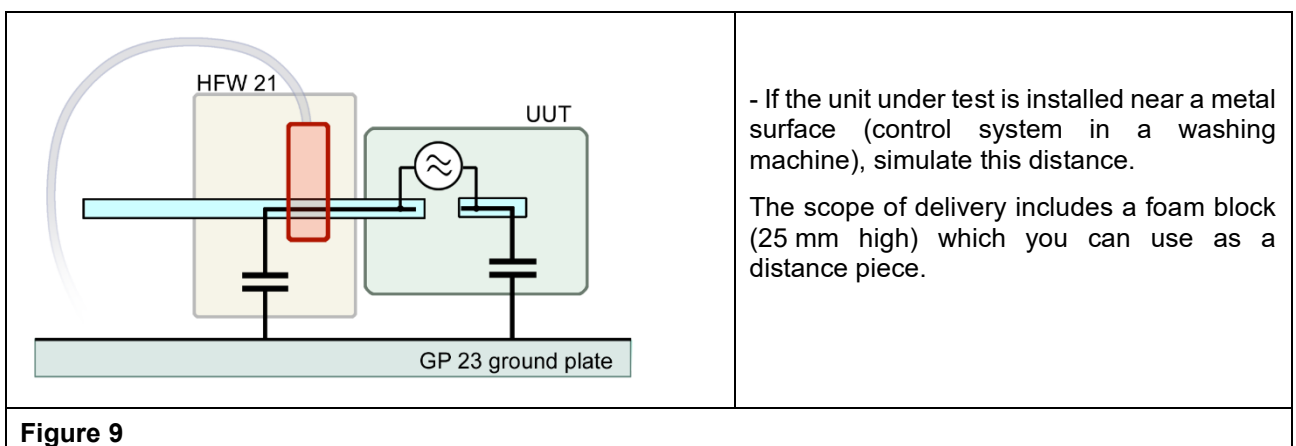
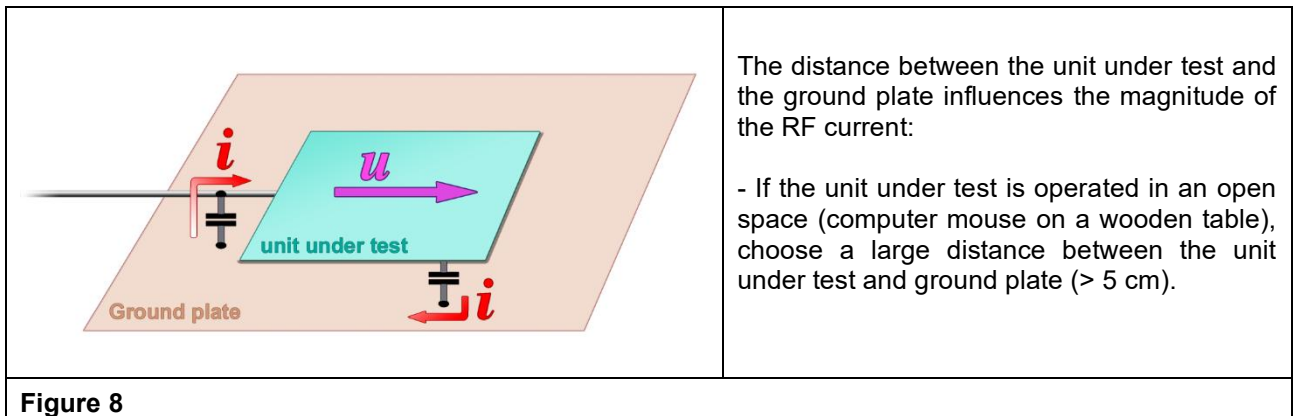
Perform another measurement with the HFW 21 to check the effect of the implemented modifications. Evaluate the modification, take other measures if necessary and only carry out a further acceptance measurement if there is a decisive improvement in the module.

## 8 Measurement set-up variants

### 8.1 Measurement of the common-mode component

#### 8.1.1 Unit under test with one cable terminal

If only one cable, e.g. the power supply cable, is connected to the unit under test, its leads are filtered first through the GP 23 ground plate and then through the HFW 21 (Input: Power and output COM). The RF current flows through the parasitic capacitance between the unit under test and ground plate to the ground plate and back to the unit under test through the HFW 21 via the power supply cables (Figure 8 and Figure 9).



The capacitance between the unit under test and ground plate is determined by the size and distance of the unit under test. The RF current flows through this parasitic capacitance. This may be caused by electric fields on the surface of the unit under test which are generated by large surface clocked bus systems.

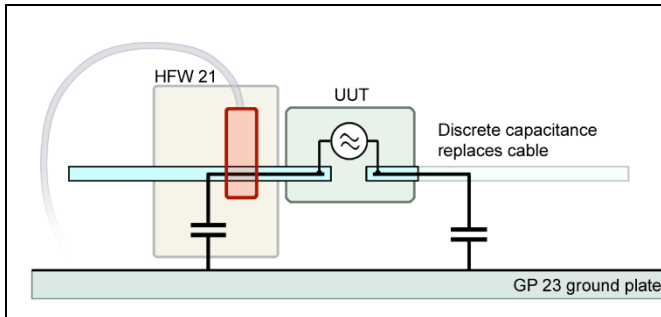
In some cases it will not be possible for you to pass the single cable through the current transformer, e.g. if

- more than two wires are needed,
- the current consumption of the unit under test is too high,
- the supply voltage is too high.

In such cases you should connect the unit under test via the usual cable and connect its GND directly to the ground plate via the HFW 21 by as short a cable connection as possible. A large part of the RF current which is normally fed to the cable will be diverted via the HFW 21 and measured. You can make this procedure more effective by inserting a choke into the cable.

### 8.1.2 Unit under test with several cable terminals

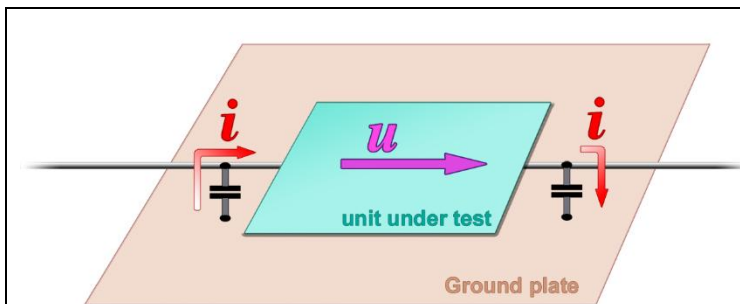
The aim is a measurement set-up which is as simple and easily comprehensible as possible. All cables that are not crucial for operating the unit under test are thus disconnected. A restricted function due to missing data, for example, is generally acceptable because essential RF sources on the module, such as the clock line and processor, are still operational in this case even if minor changes arise due to other program sequences, for example. After having found and minimized the main disturbance emissions causes, carry out respective control measurements and, if necessary, connect one cable after the other (**Figure 10** and **Figure 11**).



Replacing cables that are not crucial for operation with a link to the ground plate:

Establish a direct conductive connection from the GND terminal of the plug-and-socket connector to the ground plate instead of the cable in the simplest case.

Figure 10



You can also establish a capacitive connection from GND or Vcc, for example, to the ground plate.

Measure the influence of (clocked and operationally static) data lines via a direct capacitive connection from these data lines to the ground plate (also see 8.1.5 External data lines).

Figure 11

### 8.1.3 Unit under test with indispensable cables

If you cannot disconnect and simulate cables by an equivalent capacitance or conductive connection for functional reasons, you have to put and fix the cable on the ground plate (**Figure 12**). If the cable leaves the ground plate, use ferrites (still on the ground plate) to prevent the cable position and length outside the defined measurement set-up from interfering with the measurement result and prevent interference currents, which flow in from the surroundings via these cables from being damped.

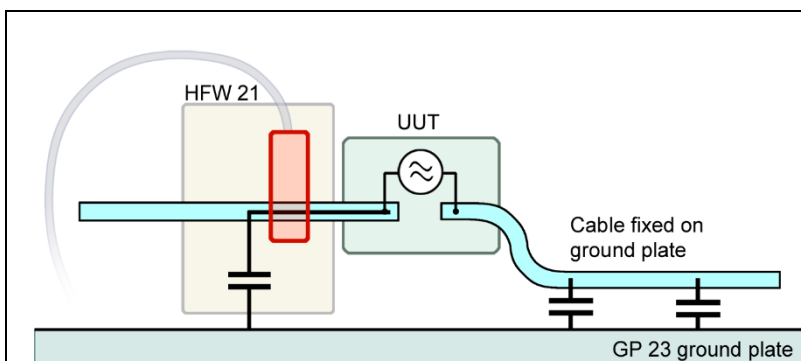
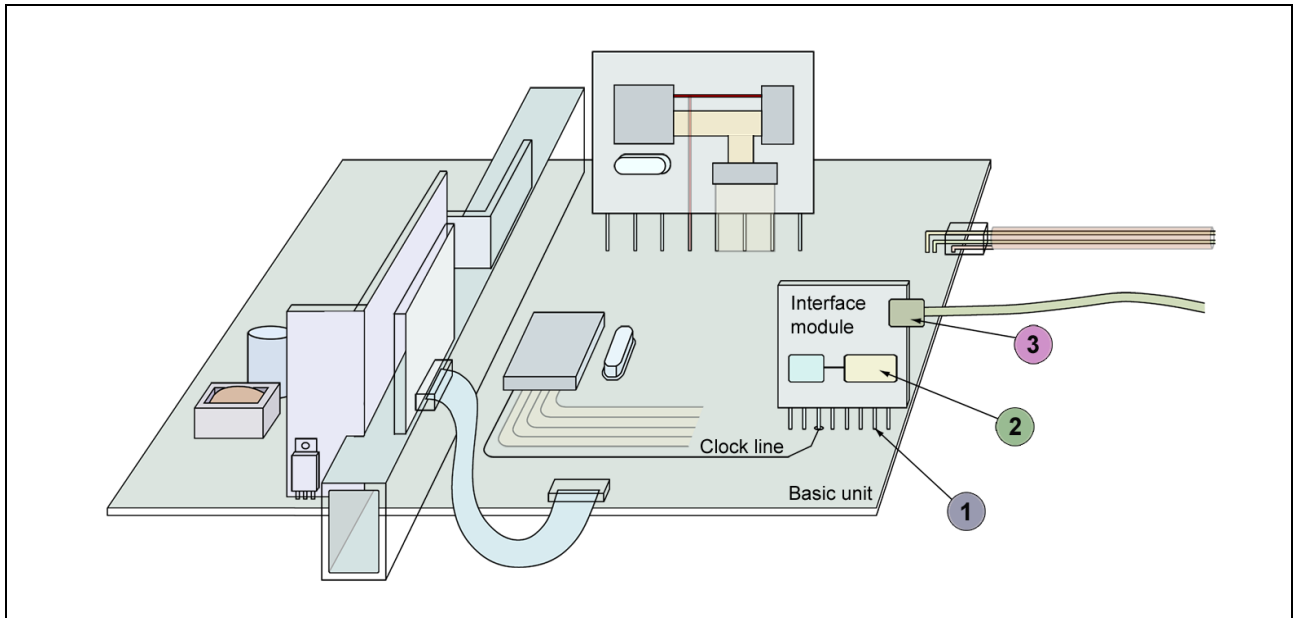


Figure 12

### 8.1.4 Example: Measurements on a complex unit under test

In many cases, different effects of various RF sources within the unit under test will first be superposed and lead to an amplification or reduction of the RF fields at particular frequencies. It is therefore important for an effective reason analysis, particularly with complex units under test comprising several modules, to dismantle the unit under test and deal with individual modules separately.

The unit under test shown in **Figure 13** has several potential disturbance emission sources. We only consider here the interface module plugged on to the basic unit as an example:



**Figure 13** RF sources on the interface module

Three RF sources are likely to cause emissions:

- 1) plug-and-socket connector between basic unit and interface module
- 2) electronic components (processor with memory chip) on the interface module
- 3) data streams generated by the interface module and fed into the connected cable

Deal with these three RF sources in succession. You will need measurement set-ups that largely blank out the other RF sources of the unit under test and those of the basic unit.

#### 1) Plug-and-socket connector between basic unit and interface module

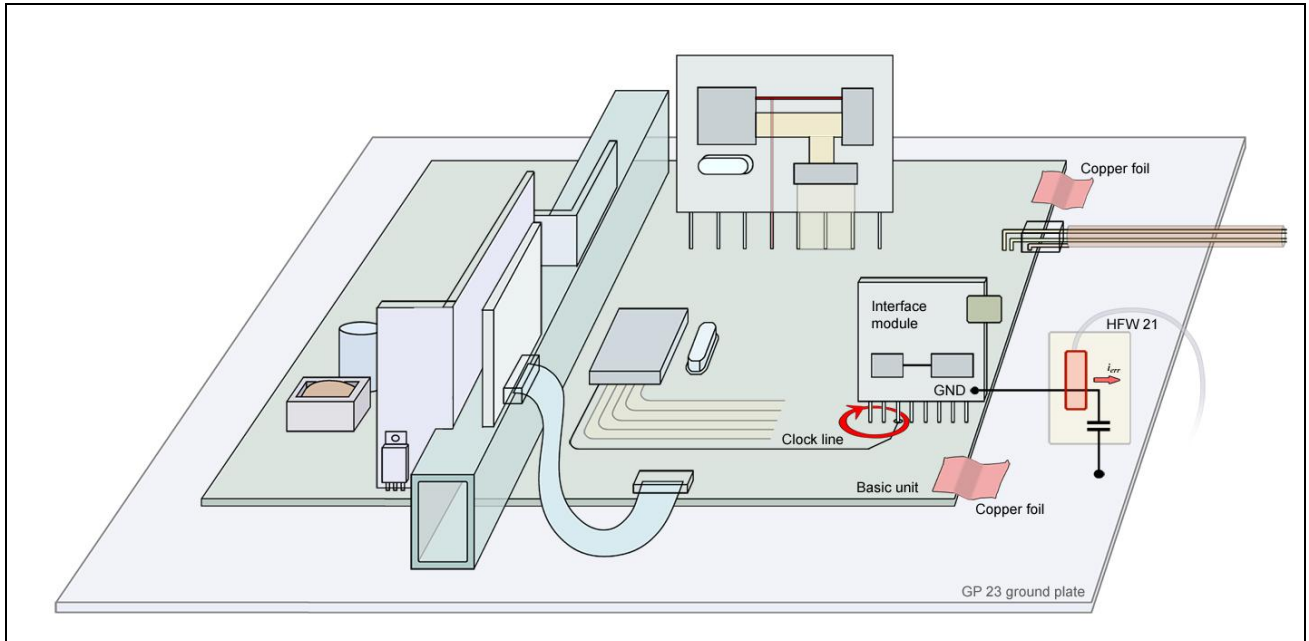
##### Assumption:

The basic unit and interface module are connected to each other via data and control lines. These lines are well protected by the basic unit and interface module in the area of the GND systems – but in the area of the plug-and-socket connector they lie in the open air. The high-frequency shares of the signals sent via these lines generate RF magnetic fields which can dissipate freely in the atmosphere and can cause voltage differences between the GND of the basic unit and that of the interface module. These voltage differences drive RF currents into the cable that is connected to the interface module and thus cause emissions (**Figure 14**).

All other potential RF sources have to be largely eliminated to measure these voltage differences. To do so, make several connections between the GND of the basic unit and the GP 23 ground plate with copper foil adhesive tape (mainly in the area of the interface module). The basic unit's GND in the area of the interface module and the ground plate are thus equipotential – the voltage differences caused by other sources are short-circuited to the greatest possible extent. Also disconnect the data cable from the interface module provided the data transfer between interface module and basic unit is not dramatically reduced by this measure.

**Measurement:**

Now briefly connect a COM output of the HFW 21 with the GND of the interface module (**Figure 14**). The voltage difference generated in the area of the plug-and-socket connector causes a compensating current to flow through HFW 21 and its capacitive connection to the ground plane back to the GND of the basic unit. This compensating current is measured with the HFW 21 and reflects the amount of the plug-and-socket connector area's share of disturbances being emitted by the whole unit under test. The effects of modifications such as filters or changing the plug assignment are directly measurable.



**Figure 14** GND of the interface module connected to the COM output of the HFW 21

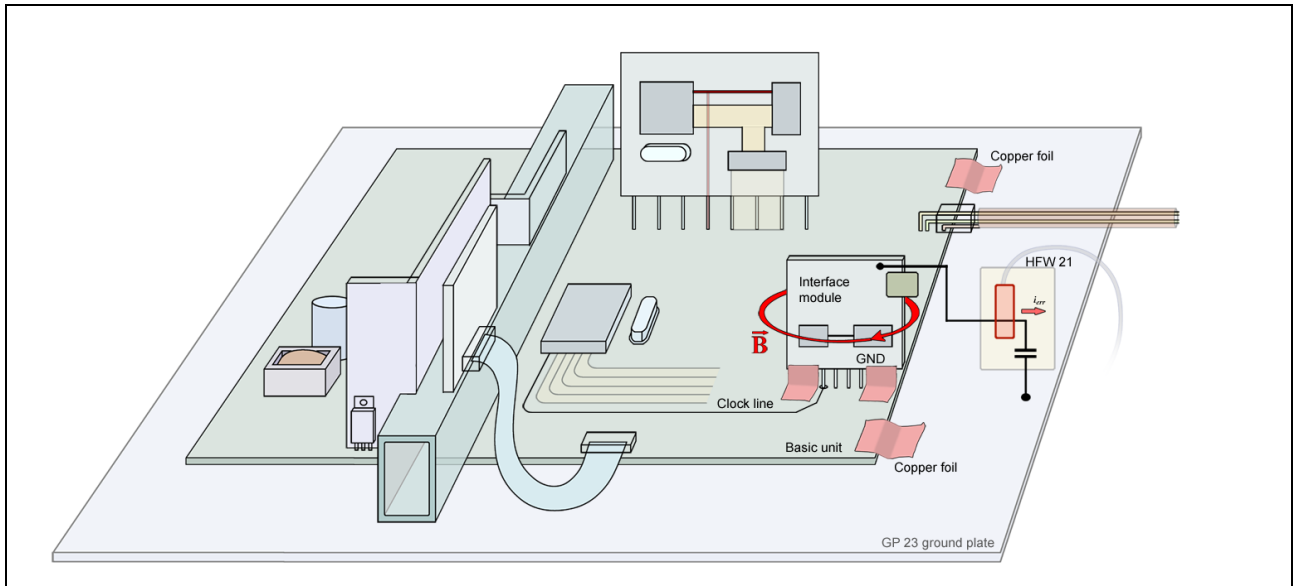
**2) Electronic components (processor with memory chip) on the interface module**

**Assumption:**

The electronic components on the interface module generate currents in the GND system of the interface module which provoke a voltage drop between the connection points of the two plug-and-socket connectors. This voltage difference is decoupled via the data cable and causes disturbance emissions.

**Measurement:**

The basic unit is still connected to the GP 23 ground plate. The remaining share of the plug-and-socket connector between interface module and basic unit is dramatically reduced by several large-area GND connections between both GND surfaces (**Figure 15**).



**Figure 15** Evaluation of the modifications with the HFW 21

Tap the voltage directly at the GND terminal of the interface plug via a short measuring cable to the COM port of the HFW 21. Thus the modifications that have been made directly on the interface module can be evaluated.

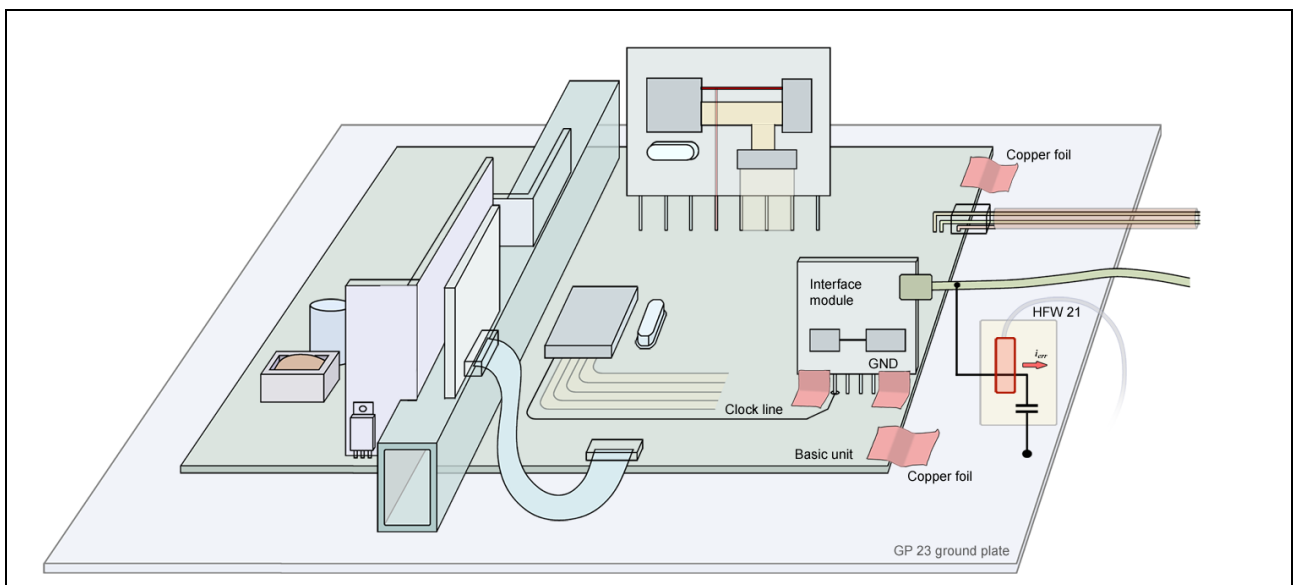
### 3) Data streams fed into the connected cable

#### Assumption:

The interface driver module feeds a RF current into the signal wires of the data cable. This current couples to the shield via the cable capacitance of signal wire - shield and flows back to the GND of the interface module. It generates a voltage difference between the shield and GND in the area of the shield connection which causes disturbances being emitted.

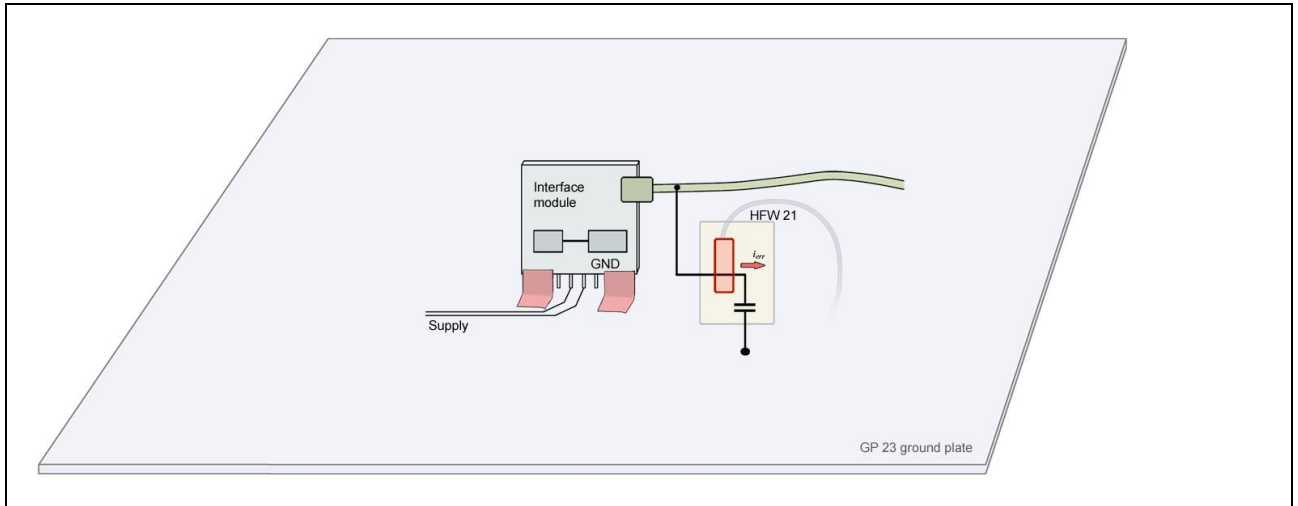
#### Measurement:

Carry out this measurement without changing the measurement set-up. Simply connect the HFW 21 directly to the shield of the plugged-in data cable (**Figure 16**). Thus the voltage drop can be detected as expected.



**Figure 16** HFW 21 detects the voltage drop on the shield of the connected data cable

This set-up has a disadvantage: the voltage differences remaining from the areas of the basic unit, plug-and-socket connector and GND of the interface module are measured as well. Wherever functionally possible, you should initially operate the interface module separately without the basic unit (**Figure 17**). The module's performance characteristics, e.g. without data being sent by the basic unit, will of course differ from those under normal operating conditions. If the clock line works and the processor is in operation, however, relative measurements of the currents and fields generated by the processor, for example, are possible. You can easily evaluate modifications to the GND and supply systems.

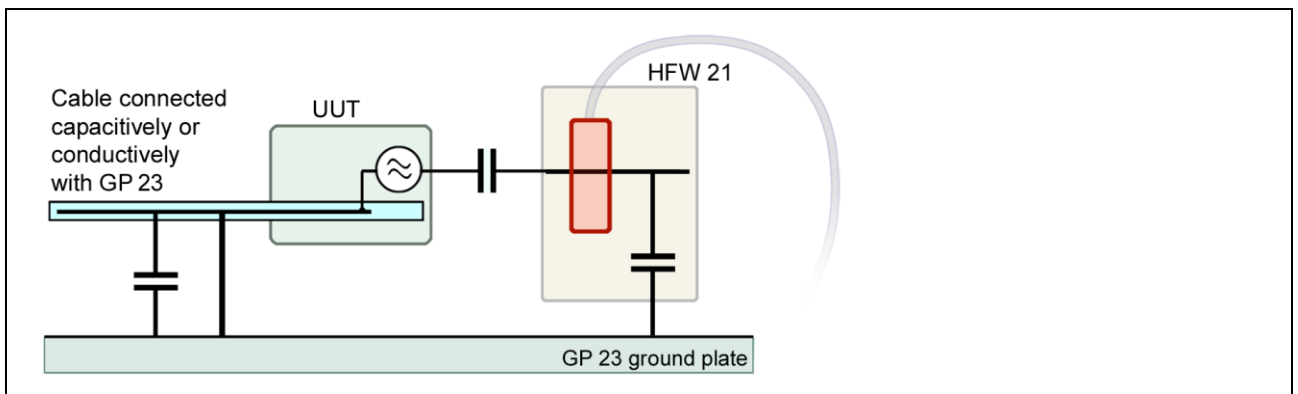


**Figure 17** Set-up without the basic unit

### 8.1.5 External data lines

#### 1) Measuring the RF current on data lines

To measure the RF current on data lines, simulate the capacitance of the line connected under normal operating conditions and lead the RF current through the RF current transformer (**Figure 18**). The RF current circuit is closed through the capacitance of other lines relative to the ground plate or through capacitive or conductive coupling between the unit under test and ground plate (e.g. with battery-operated devices). This procedure is particularly suitable for dimensioning data line filters. If the unit under test drives a remote LCD display via a ribbon cable, for example, disconnect the lines to the display on the unit under test side and only connect one line to one of the COM outputs of the HFW 21 via an equivalent capacitance and optimize this line first. Apply the filter circuit you have found to other signal lines later on.

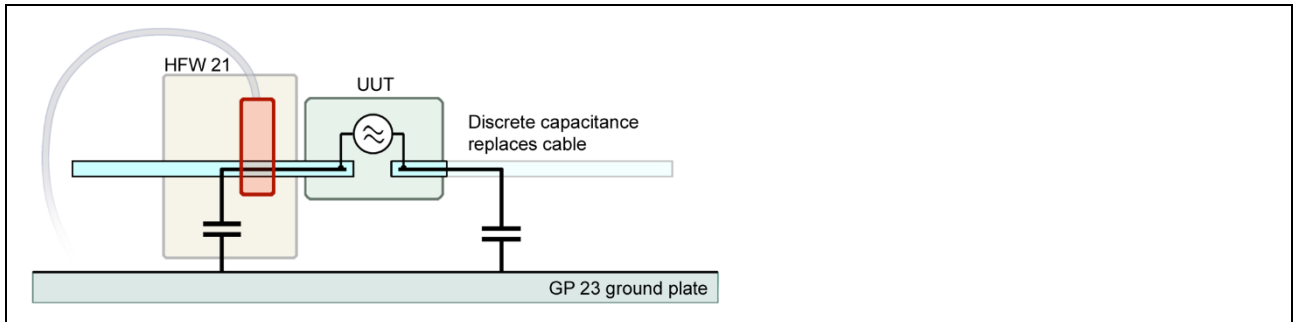


**Figure 18**

## 2) Measuring the effect on the unit under test

Simultaneous measuring of the RF current on many lines, such as those of a ribbon cable, is not possible. In such cases you have to carry out the measurement according to **Figure 19**:

Do not measure the RF current directly on the signal lines but on another cable (e.g. on the opposite power supply connection) or, if there is no other cable present, directly on the GND as described under 8.1.1. Replace the data lines with capacitances relative to the GP 23 ground plate.



**Figure 19**

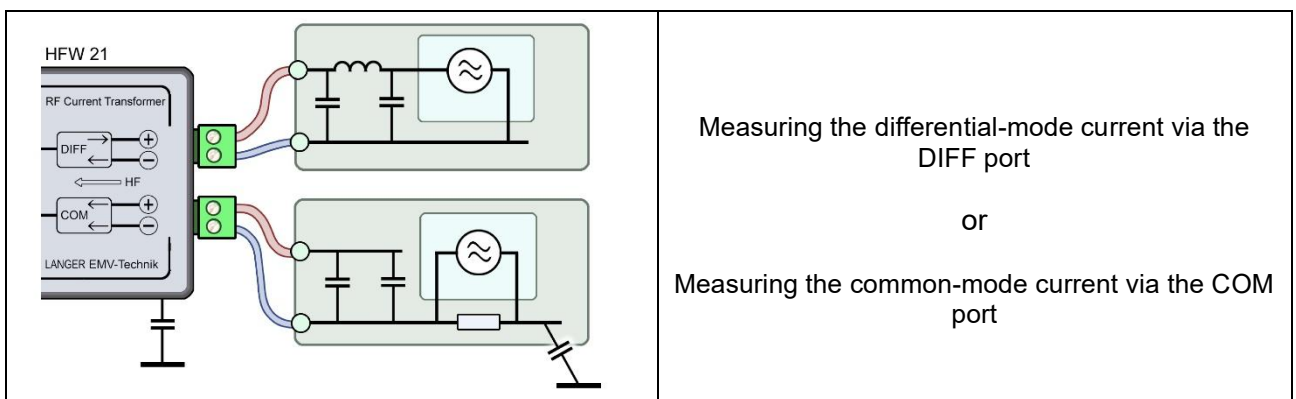
## 8.2 Measurement of the differential-mode component

Beside the common-mode currents measured so far (the RF currents in all wires of a cable travel in the same direction), differential-mode currents, which are mainly generated in the power supply unit of DC/DC converters or by clocked loads (e.g. via PWM) are of interest in the lower frequency range. The RF current transformer enables these measurements via the DIFF port (**Figure 20**).

According to the disturbance emission mechanism described under chapter 0, this differential-mode current does not result in any disturbance emissions. But since it also flows in the ground of the chassis or GND connections between different devices, voltage differences develop between these devices. These in turn cause compensating currents (common-mode currents) which cause disturbance emissions.

The differential-mode currents in units under test containing a DC/DC converter or a similar device have to be measured and, if necessary, reduced by capacitors or chokes because these currents are partially transformed into critical common-mode currents according to the described mechanism.

The output signal is damped (saturation effect) depending on the power consumption of the unit under test (see point 9) in the frequency range below 10 MHz if the RF differential-mode current is measured on the supply lines of the unit under test. This effect does not occur above this frequency or if the measurement is carried out via the COM common-mode output.



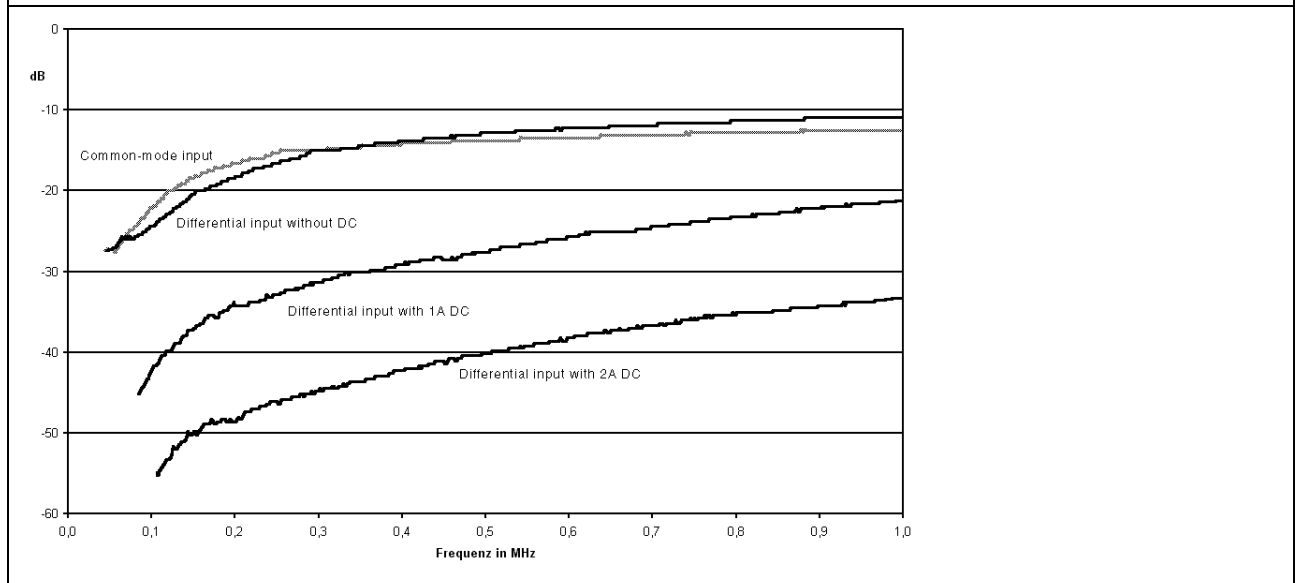
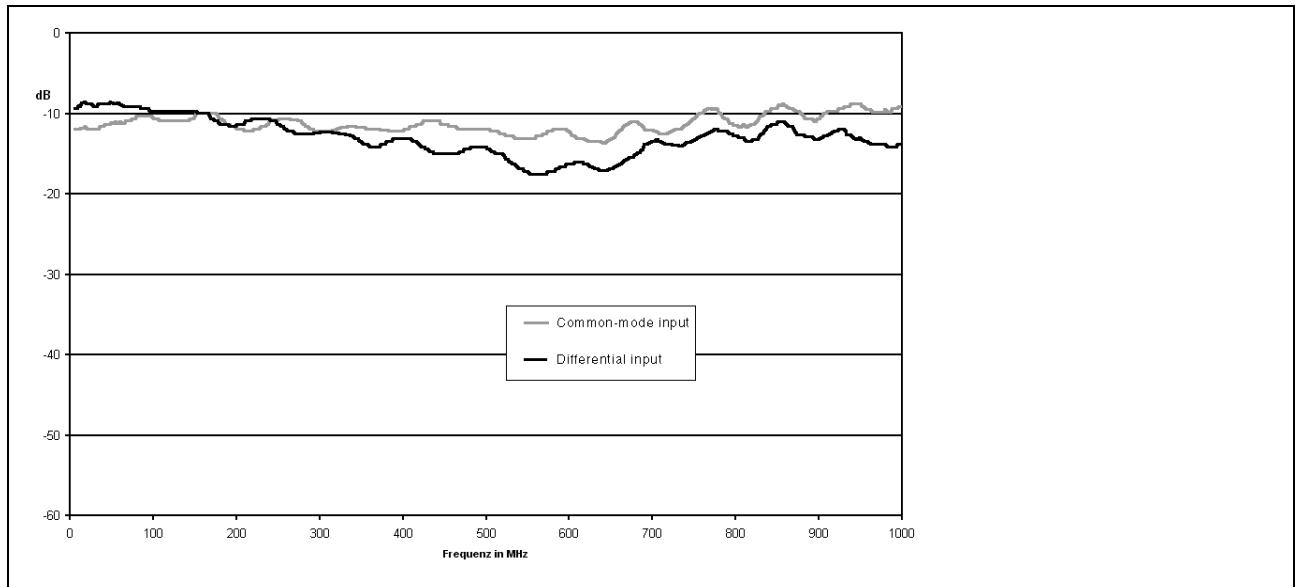
Measuring the differential-mode current via the DIFF port  
  
or  
  
Measuring the common-mode current via the COM port

**Figure 20**

## 9 Technical parameters

### 9.1 HFW 21 RF current transformer:

<b>Max. continuous current</b>	10 A
<b>Max. operating voltage</b>	50 V



**Figure 21** HFW 21 transfer performance

### 9.2 HFA 21 RF bypass

<b>Capacitances</b>	10 pF to 100 nF
<b>Max. operating voltage</b>	50 V

## 10 Information on Recycling and Disposal

In accordance with the WEEE Directive 2012/19/EU (Waste of Electrical and Electronic Equipment), the following must be observed:

At the end of its service life, this product should be taken to a suitable disposal facility for recycling and disposal. Do not dispose of with household waste.



## **11 Customer service**

Please contact us if you have any questions, comments or suggestions.

You can contact us:

Monday – Friday  
8:00 Uhr bis 15 Uhr (CET)

Contact us at:

Address: Langer EMV-Technik GmbH  
Nöthnitzer Hang 31  
01728 Bannewitz  
Germany

Internet: <https://www.langer-emv.com/>  
E-mail: [sales@langer-emv.de](mailto:sales@langer-emv.de)  
Phone: +49 (0) 351-430093-0  
Fax: +49 (0) 351-430093-22

### **Calibration**

We recommend having the product calibrated every two years by the manufacturer Langer EMV-Technik GmbH or by a certified distributor.

## 12 Warranty

Langer EMV-Technik GmbH shall remedy all defects attributable to material or manufacturing faults within the statutory warranty period by repairing the product or supplying replacement parts.

**This guarantee is only granted on condition that:**

- the information and instructions in the operating instructions are observed.

**The guarantee expires if:**

- an unauthorized repair is carried out on the product
- the product is modified
- the product is not used as intended

This document may not be copied, reproduced or processed, duplicated or distributed using electronic systems, either in whole or in part, without the prior written permission of Langer EMV-Technik GmbH. The management of Langer EMV-Technik GmbH accepts no liability for damage resulting from the use of this printed information.

LANGER  
EMV-Technik GmbH

Noethnitzer Hang 31  
DE-01728 Bannewitz  
www.langer-emv.de

Tel.: +49 351/430093-0  
Fax: +49 351/430093-22  
sales@langer-emv.de