

P750

150Ω高频电压表



Short description

P750 高频电压表带有150Ω的耦合电路，它根据IEC 61967-4测量集成电路引脚的高频电压。P750探头具备高阻抗的电容耦合输入，因此能够测量受测物上不同引脚的射频电压。

Technical parameters

频率范围	150 kHz ... 3 GHz
输入电阻	150 Ω
测量输出	50 Ω, SMB
电压传递系数	-15.2 dB
最大直流输入电压	50 V
最大射频输入电压	3.5 V

频率特性

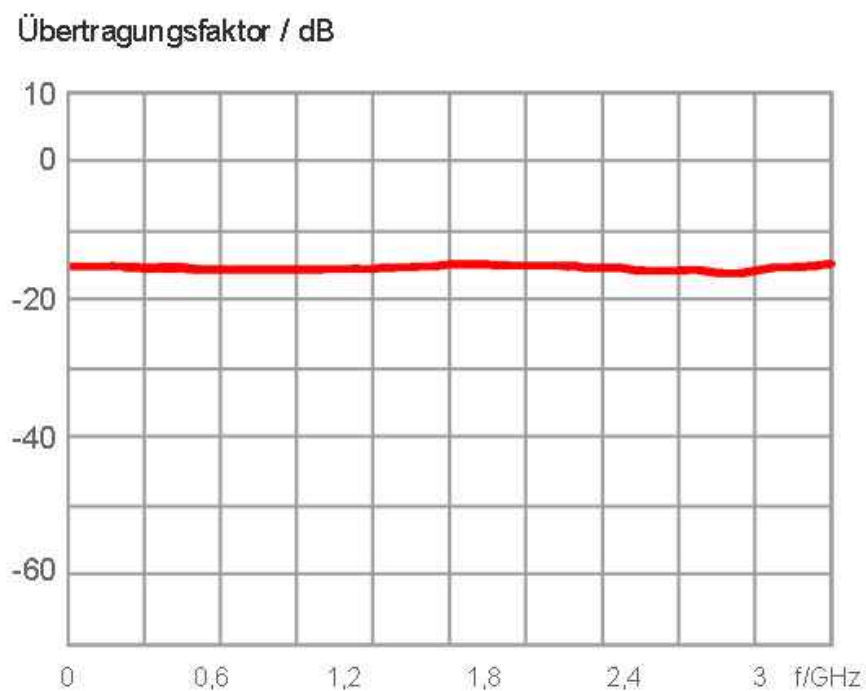

等效电路图

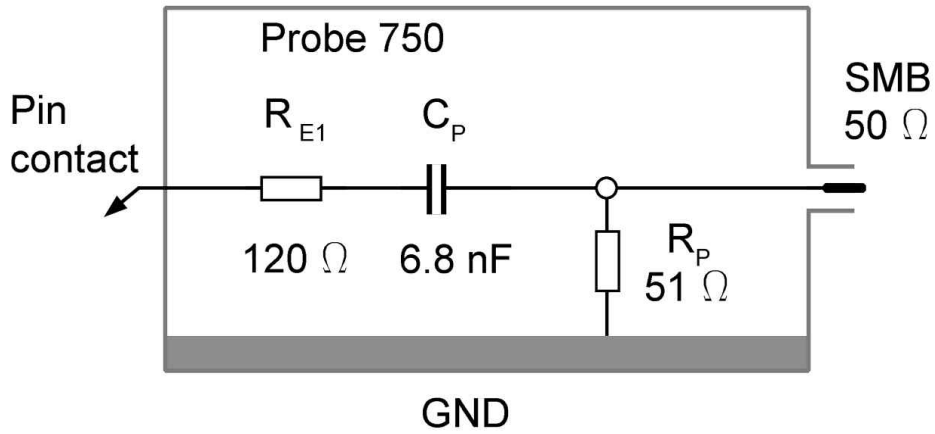

安装视图 01

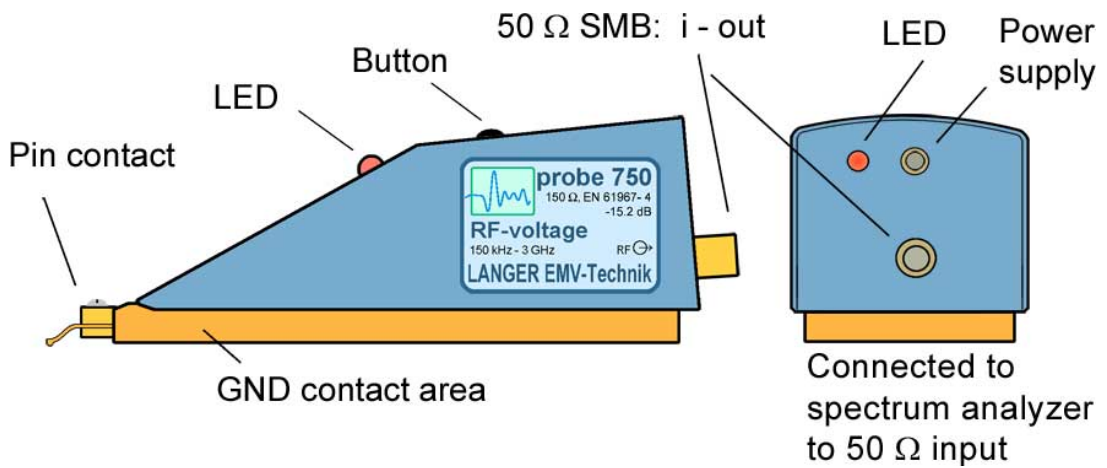

P750

150Ω高频电压表

Application with P750

