



# RF coupling into IC pins

DPI method

## P500 measuring system

### Brief description

1. Set up

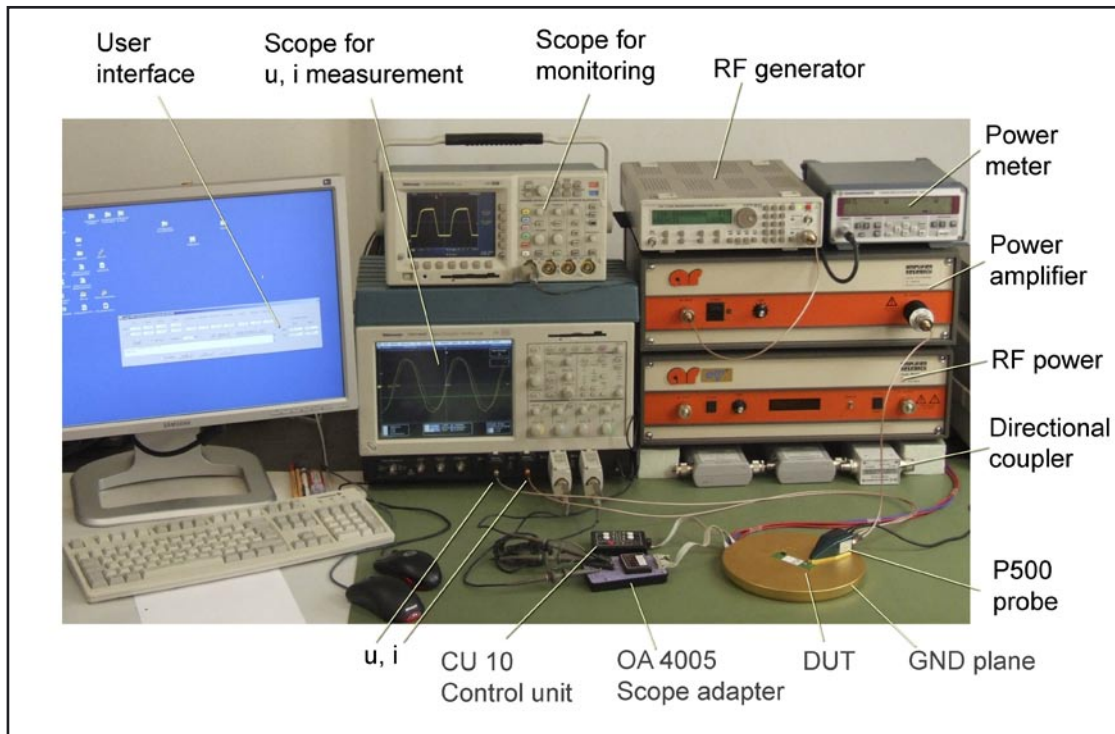

Figure 01:  
Measuring set-up

The measurement setup (Figure 01) basically comprises:

- P500 probe with RF lead-through, voltmeter and ammeter
- Test IC (DUT), GND plane
- Scope for measuring the RF values
- Power amplifier, RF generator
- PC with „ProbeControl“ software for measuring sequence automation  
(Optional: directional coupler, power meter, monitoring scope ...)

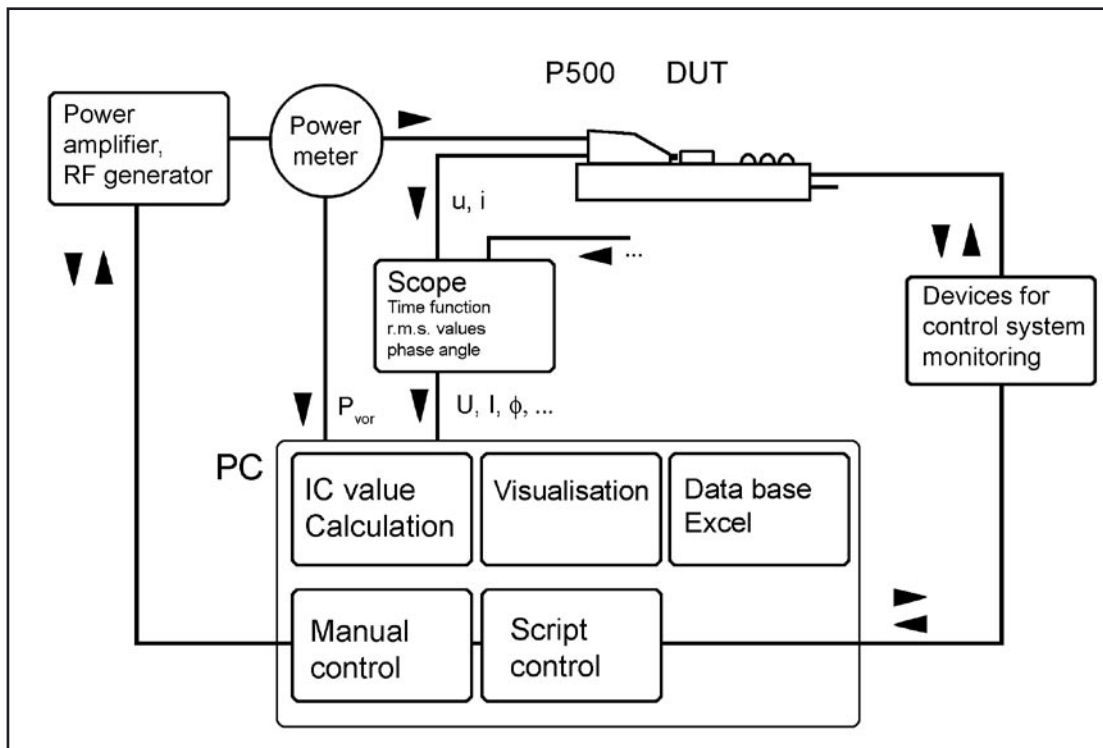

Figure 02:  
Block diagram of the  
measuring set-up

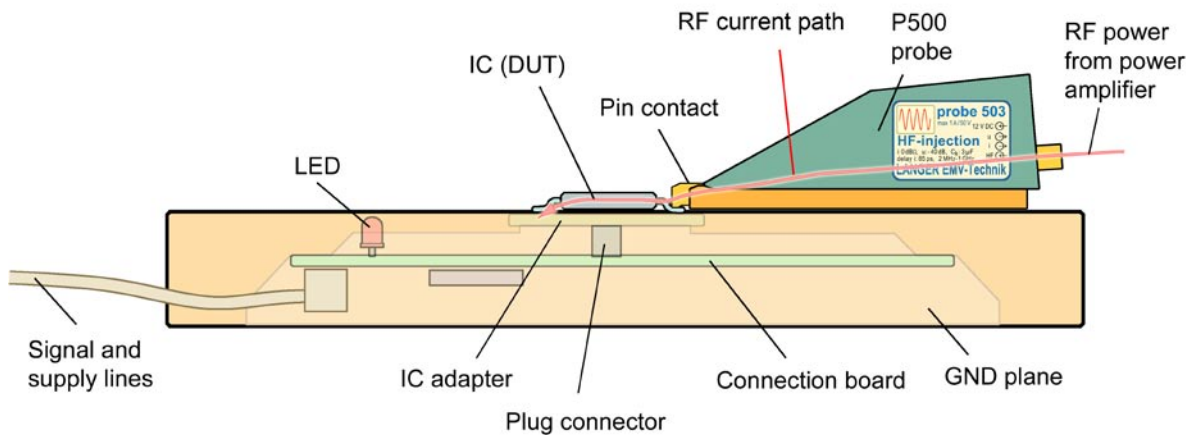

Figure 03: DUT measuring set-up, section through the GND plane

## 2. Description (Figure 02)

The RF is led from the power amplifier to the test IC (DUT) via the P500 probe (Figure 03). A voltmeter and ammeter are located inside the P500 probe near its tip. The RF voltage and current are measured as a function of time and the results are transmitted to a scope. The r.m.s. values and phase angle are calculated on the basis of the time characteristics in the scope.

Further calculations ( $p(t)$ ,  $P$ , FFT...) can be performed depending on the scope's features. The results are transmitted to the PC (RS232, GPIB, VXI). The PC can also control further devices (power meter, DUT monitoring scope, etc.) and read out their data. These values and any other values (bool, int, float, string (e.g. remarks)) are entered in an Excel spreadsheet or ODBC database. The „ProbeControl“ software is responsible for handling and controlling this information.

Two different GND plane versions can be used.

1. GND 20 with a passive connection board and jumpering panel with soldering pads.
2. GND 22 CB 0706 connection board with  $\mu C$ , USB, USB hub with 2 ports, 3x current / voltage measurement, SPI, analogue and digital ports and jumpering panel with soldering pads.

Frequency-limited DUT signals can be led to the OA4005 (4 channel) scope adapter. Signal state and spikes can be displayed for each channel via LED.

The CU10 control unit can be used to turn off the DUT power supplies (Emergency OFF) and control two signals via pushbuttons and switches.

(P600) current and (P700) voltage measuring probes can be placed on the GND plane and brought into contact with IC pins. These probes can be used to measure RF emanating from the pins (...3 GHz)

The measuring sequence is controlled by hand, semi-automatically or automatically with a script from the PC user interface (Figure 04). The user interface etc. is part of the „ProbeControl“ software.

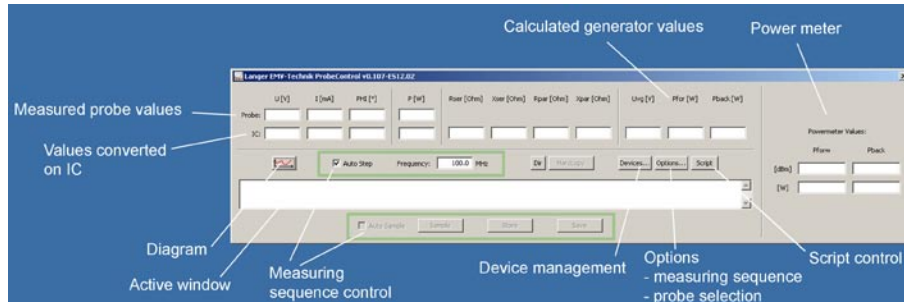

Figure 04:  
User interface of the  
„ProbeControl“ software

The voltmeter and ammeter feature constant and frequency-dependent correction factors. The constant correction factors can be taken into account in the scope (realistic scope image) or PC whereas the frequency-dependent correction factors are only taken into consideration in the PC. The probe measures the voltage that is present on the pin and the current that flows into the pin. The parasitic elements R, L, C are located between the tip and the voltmeter and ammeter. u, i have to be corrected relative to the tip (IC pin) using the equivalent elements for certain adaptations (unequal 50 Ohm) and frequency ranges.

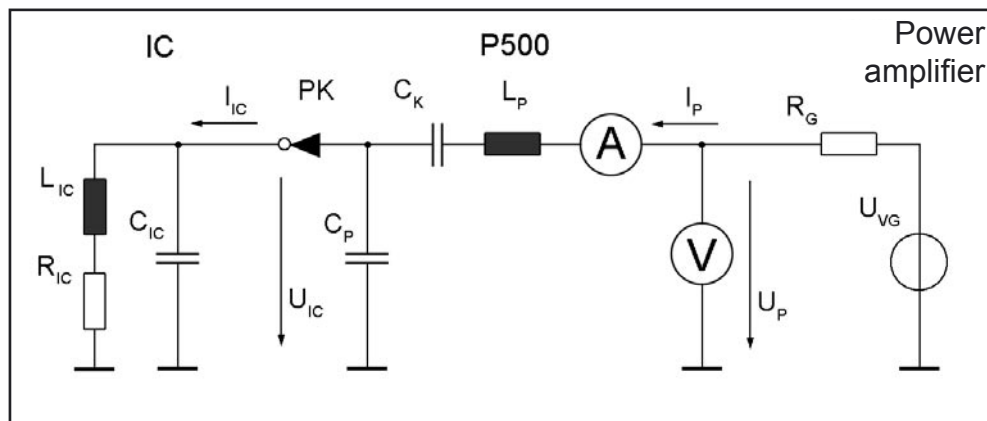

Figure 05:  
Equivalent circuit diagram  
of the measuring set-up

Figure 05 shows a simplified equivalent circuit diagram. The probe's equivalent circuit diagram of the calculation program comprises more than 20 equivalent elements.

The conversion is performed on the PC with a calculation program that is part of the „ProbeControl“ software.